

MANDRINO PRINCIPALE E SECONDARIO
MAIN AND SECONDARY SPINDLE
CABEZAL PRINCIPAL Y SECUNDARIO
HAUPTSPINDEL / GEGENSPINDEL
主軸および第2の軸
главный и дополнительный
ШПИНДЕЛЬ

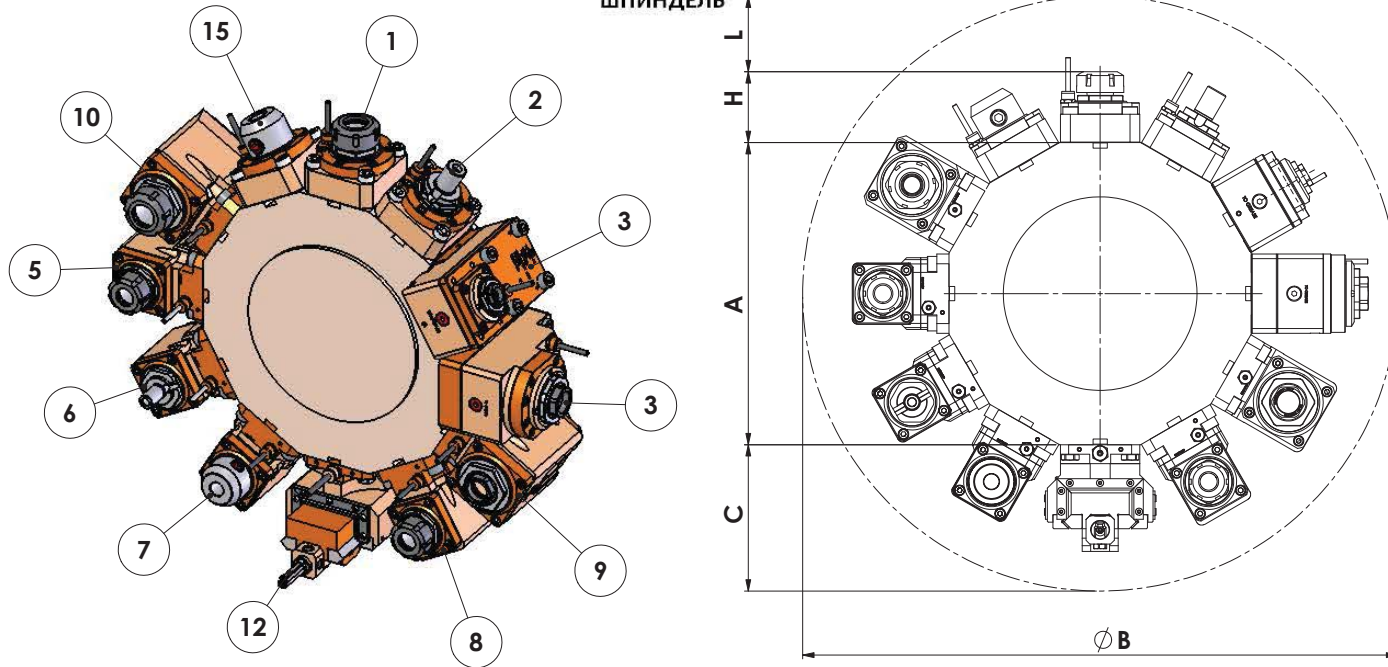

* Su macchine B545 - B550 - B565 non arriva in centro mandrino
On B545-B550-B565 machines it doesn't reach spindle's center

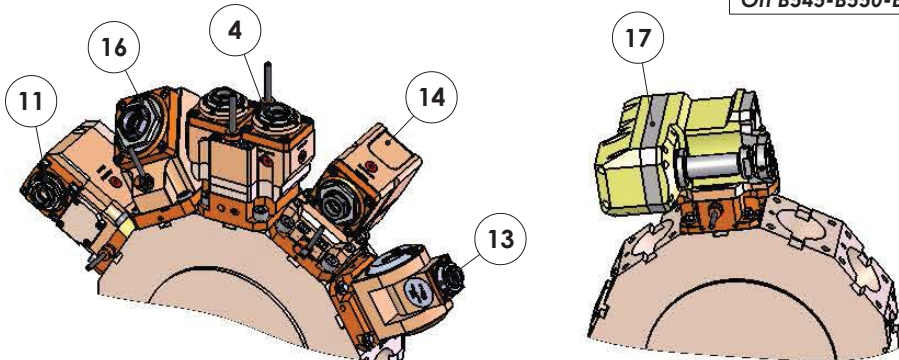

MACCHINA	LUNGHEZZA UTENSILE TOOL LENGTH		
	A	ØB	C
B545-550-565	320	610	145
B445-B470	320	630	155
B650-B1200	370	610	120
B301	320	575	127.5

Pos	Descrizione	Note	Codice
17	LT-SAW D55 22 2,5:1 H90 BI	NEW	05077600-R011
16	LT-A45 D55 ER32F LR1:1H104BI	NEW	05077500-R011
16	LT-A45 D55 ER32F LR2:1H104BI	NEW	05077300-R011
15	LT-S D55 WELDON-20 H80 BI	NEW	05077400-R011
14	LT-A D55 ER25F LR OFS H78 BI	*	05077100-R011
14	LT-A D55 ER25F LR RF OFS H78BI	*	05077000-R011
13	LT-T D55 ER20F H75-155 BI		05075400-R011
13	LT-T D55 ER16F H63-132 BI		05075300-R011
12	LT-A ST35 D55 C12 CR-AY H90 BI		05072200-R011
12	LT-A ST35 D55 C12 H90 BI		05072100-R011
11	LT-A D55 ER20F LR 1:2 H100 BI		05076700-R011
10	LT-A D55 ER25 LR 1:2 H100 BI	NEW	05077200-R011
10	LT-A D55 ER32 LR 2:1 H100 BI		05076600-R011
10	LT-A D55 ER32 LR RF 2:1 H100BI		05076500-R011
10	LT-A D55 ER32 LR 2:1 H70 BI	*	05076400-R011
10	LT-A D55 ER32 LR RF 2:1 H70 BI	*	05076300-R011
10	LT-A D55 ER32 LR H100 BI		05075000-R011
10	LT-A D55 ER32 LR RF H100 BI		05074900-R011
10	LT-A D55 ER32 LR H70 BI	*	05074800-R011
10	LT-A D55 ER32 LR RF H70 BI	*	05074700-R011
9	LT-A D55 ER32F-32F H100 BI		05075200-R011
9	LT-A D55 ER32F-32F H70 BI	*	05075100-R011
8	LT-A D55 ER25-25 H100 BI		05074600-R011
8	LT-A D55 ER25-25 H70 BI	*	05074500-R011
7	LT-A D55 WELDON-20 LR H100 BI		05074400-R011
7	LT-A D55 WELDON-16 LR H100 BI		05074300-R011
7	LT-A D55 WELDON-20 LR H70 BI	*	05074200-R011
7	LT-A D55 WELDON-16 LR H70 BI	*	05074100-R011
6	LT-A D55 DIN138-22 LR H100 BI		05074000-R011
6	LT-A D55 DIN138-16 LR H100 BI		05073900-R011
6	LT-A D55 DIN138-22 LR H70 BI	*	05073600-R011
6	LT-A D55 DIN138-16 LR H70 BI	*	05073500-R011
5	LT-A D55 ER25 LR H100 BI		05073800-R011
5	LT-A D55 ER25 LR RF H100 BI		05073700-R011
5	LT-A D55 ER25 LR H70 BI	*	05073400-R011
5	LT-A D55 ER25 LR RF H70 BI	*	05073300-R011
4	LT-S2 D55 ER20F-20F 1:1 H122BI		05076800-R011
4	LT-S2 D55 ER20F-20F 1:2 H122BI		05076900-R011
3	LT-S D55 ER32F OF51 2:1 H115BI		05076200-R011
3	LT-S D55 ER32F OF51RF2:1H115BI		05076100-R011
3	LT-S D55 ER25F OF72 H85 BI		05075800-R011
3	LT-S D55 ER25F OF72 RF H85 BI		05075700-R011
3	LT-S D55 ER20F OF78 1:3 H90 BI		05075600-R011
3	LT-S D55 ER20F OF78RF1:3 H90BI		05075500-R011
2	LT-S D55 DIN138-22 H57 BI		05073000-R011
2	LT-S D55 DIN138-16 H47 BI		05072900-R011
1	LT-S D55 ER32 H75 BI		05072700-R011
1	LT-S D55 ER32 RF H75 BI		05072800-R011
1	LT-S D55 ER25 RF H65 BI		05072600-R011
1	LT-S D55 ER25 H65 BI		05072500-R011

SMW AUTOBLOK GROUP

PROPRIETA' RISERVATA - Il presente disegno e' di proprieta' della MARIO PINTO SpA e non potra' essere comunicato a terzi o riprodotto in tutto o in parte senza il consenso scritto della stessa.

NOTICE - This drawing is property of MARIO PINTO SpA ITALY and shall not be reproduced, duplicated or copied in whole or in part, nor shall it be released to others without the written permission of the owner.

Diese Zeichnung darf ohne schriftliche Genehmigung von MARIO PINTO SpA ITALIEN weder kopiert noch dritten Personen mitgeteilt werden

MARIO PINTO TORINO MARIO PINTO S.p.A.	PORTAUTENSILI PER TORRETTE MOTORIZZATE	BIGLIA	
SCALE/SCALA	DATE/DATE	DRAWN BY/DISEGN.	CHECKED/VISTO
	26-02-2015	IANNUZZI	
WEIGHT/PESO	ASSEMBLY/COMPLESS.	DATA	FIRMA
		17/04/2015	
THE COMPANY GUARDS ITS DRAWINGS ACCORDING TO THE LAW		DRAWING/DISEGNO	
		5010 8555	

MANDRINO PRINCIPALE E SECONDARIO
MAIN AND SECONDARY SPINDLE
CABEZAL PRINCIPAL Y SECUNDARIO
HAUPTSPINDEL / GEGENSPINDEL
主軸および第2の軸
ГЛАВНЫЙ И ДОПОЛНИТЕЛЬНЫЙ ШПИНДЕЛЬ

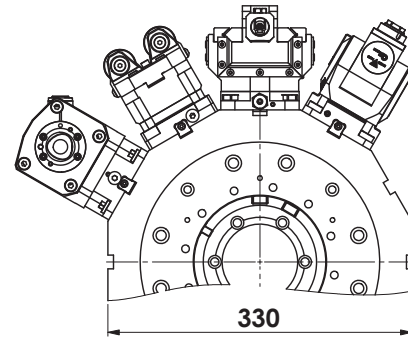
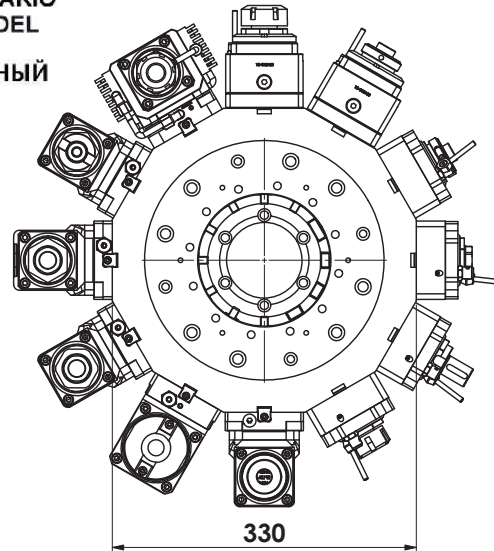
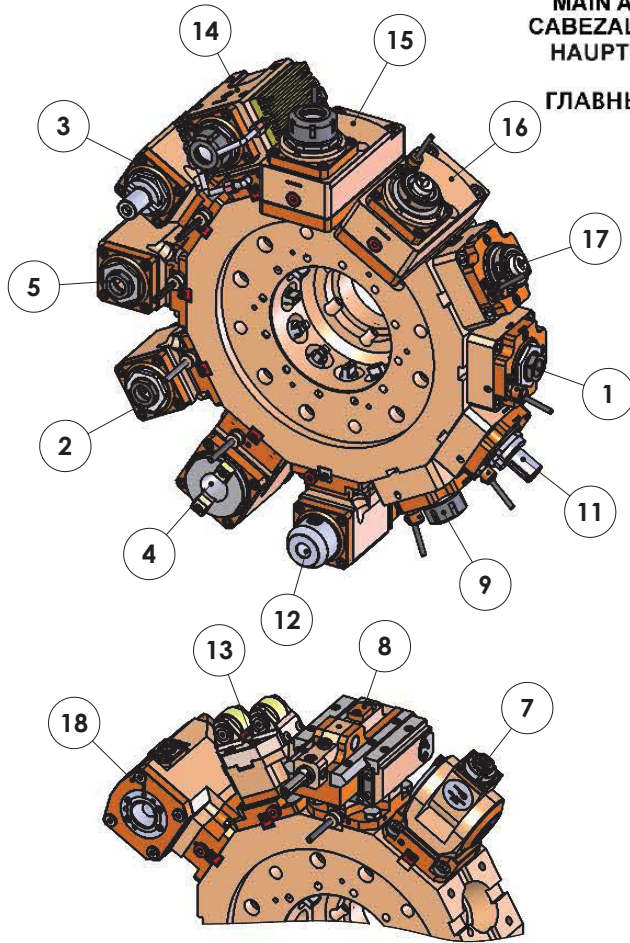

MANDRINO SECONDARIO
SECONDARY SPINDLE
CABEZAL SECUNDARIO
GEGENSPINDEL
第2主軸
ДОПОЛНИТЕЛЬНЫЙ ШПИНДЕЛЬ

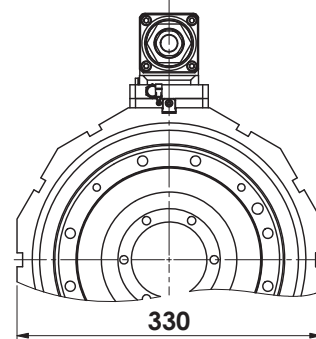
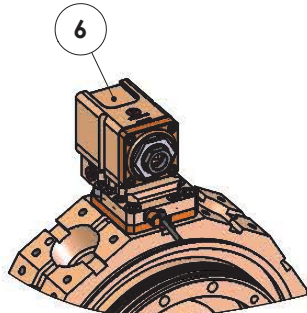

18	LT-A BMT55 C4 LR RF H-PR H85	NEW	05301400-R011
17	LT-S BMT55 HSK40 H64	NEW	05301000-R011
16	LT-S BMT55 HSK40 OFS75 2:1 H95	NEW	05302900-R011
15	LT-S BMT55 ER32 OFS75 2:1 H112	NEW	05303000-R011
14	LT-A BMT55 ER25 1:2 KR H70	NEW	05301500-R011
13	SUPPORT ALB AX 20-100 BMT55		05128700-R011
12	LT-A BMT55 WELDON-16 RF H85		05302800-R011
12	LT-A BMT55 WELDON-16 RF H70		05128600-R011
11	LT-S BMT55 DIN138-22 H60 DW		05120500-R011
11	LT-S BMT55 DIN138-16 H57 DW		05127700-R011
9	LT-S BMT55 ER25 RF H74 DW		05128500-R011
9	LT-S BMT55 ER25 H74 DW		05128400-R011
8	LT-A ST65 BMT55 C16 H110		05301700-R011
8	LT-A ST37.5 BMT55 C12 H90 DW		05127600-R011
8	LT-A ST35 BMT55 C12 CR-AY H90		05128800-R011
8	LT-A ST35 BMT55 C12 H90 DW		05128200-R011
7	LT-T BMT55 ER16F H63-132 DW		05121500-R011
6	LT-A BMT55 ER25FRFOFS1:1.75H78		05127800-R011
6	LT-A BMT55 ER25F RF OFS H70 DW		05120900-R011
6	LT-A BMT55 ER25F OFS H70 DW		05120800-R011
5	LT-A BMT55 ER25F-25F H85		05302700-R011
5	LT-A BMT55 ER25F-25F H70 DW		05120600-R011
4	LT-A BMT55 ISO-BT30 L-R RF H70		05121400-R011
4	LT-A BMT55 ISO-BT30 L-R H70		05121300-R011
3	LT-A BMT55 DIN138-27 H85		05302600-R011
3	LT-A BMT55 DIN138-22 H85		05302500-R011
3	LT-A BMT55 DIN138-27 H70 DW		05128100-R011
3	LT-A BMT55 DIN138-22 H70 DW		05120400-R011
2	LT-A BMT55 ER32F RF H85		05302000-R011
2	LT-A BMT55 ER32F H85		05301900-R011
2	LT-A BMT55 ER32F RF H70		05302400-R011
2	LT-A BMT55 ER32F H70		05302300-R011
2	LT-A BMT55 ER25F RF H85		05302200-R011
2	LT-A BMT55 ER25F H85		05302100-R011
2	LT-A BMT55 ER25F RF H70 DW		05120300-R011
2	LT-A BMT55 ER25F H70 DW		05120200-R011
1	LT-S BMT55 ER32F RF H66 DW		05128000-R011
1	LT-S BMT55 ER32F H66 DW		05127900-R011
1	LT-S BMT55 ER25F RF H53.5		05120700-R011
1	LT-S BMT55 ER25F H53.5 DW		05121000-R011
Pos	Descrizione	Note	Num. parte

SMW AUTOBLOK GROUP

PROPRIETA' RISERVATA - Il presente disegno e' di proprieta' della MARIO PINTO SpA e non potra' essere comunicato a terzi o riprodotto in tutto o in parte senza il consenso scritto della stessa.

NOTICE - This drawing is property of MARIO PINTO SpA ITALY and shall not be reproduced, duplicated or copied in whole or in part, nor shall it be released to others without the written permission of the owner.

Diese Zeichnung darf ohne schriftliche Genehmigung von MARIO PINTO SpA ITALIEN weder kopiert noch dritten Personen mitgeteilt werden

MARIO PINTO TORINO MARIO PINTO S.p.A.	PORTAUTENSILI PER TORRETTE MOTORIZZATE	BMT	
SCALE/SCALA	DATE/DATE 06-11-2014	DRAWN BY/DISEGN. D. JALLIN	CHECKED/VISTO
			N. REVISED/MODIFICA ASSEMBLY/COMPLESS.
			DATA FIRMA 7/04/2015
WEIGHT/PESO Machined ES/EN		THE COMPANY GUARDES ITS DRAWINGS ACCORDING TO THE LAW	
		5010 8410	

MANDRINO PRINCIPALE E SECONDARIO
MAIN AND SECONDARY SPINDLE
CABEZAL PRINCIPAL Y SECONDARIO
HAUPTSPINDEL / GEGENSPINDEL
主軸および第2の軸
главный и дополнительный ШПИНДЕЛЬ

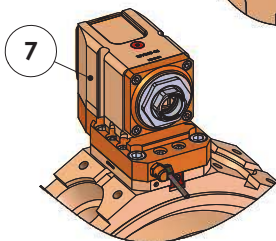
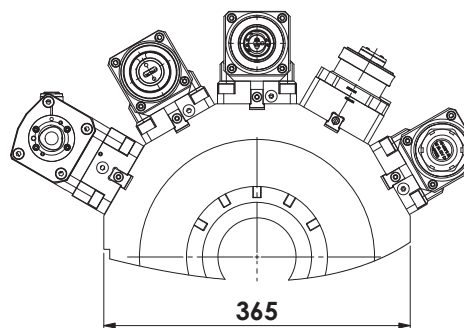
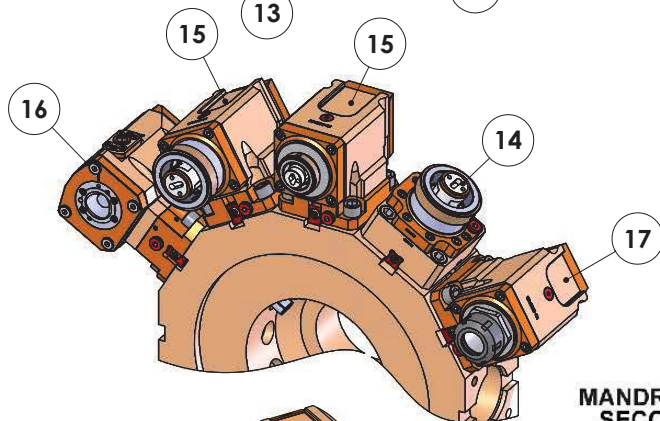
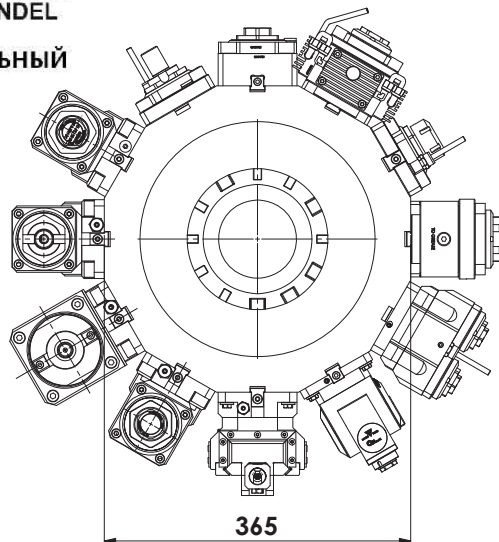
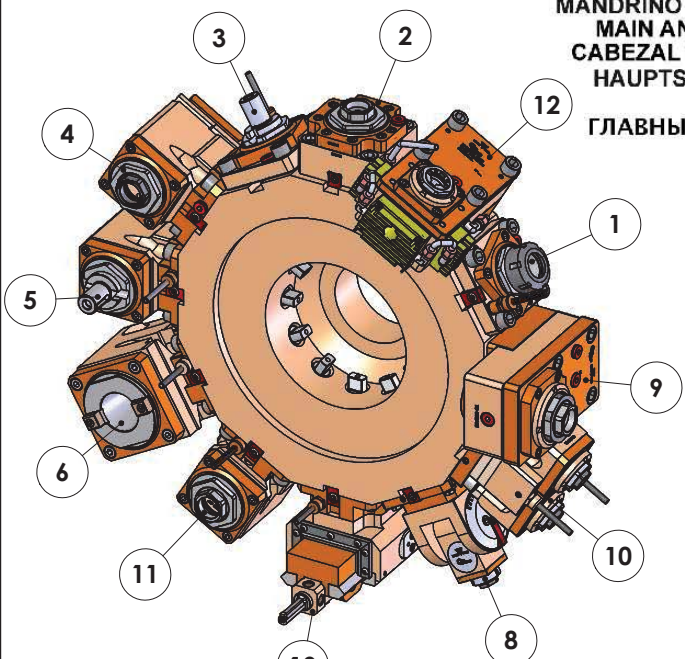

MANDRINO SECONDARIO
SECONDARY SPINDLE
CABEZAL SECONDARIO
GEGENSPINDEL
第2主軸
дополнительный ШПИНДЕЛЬ

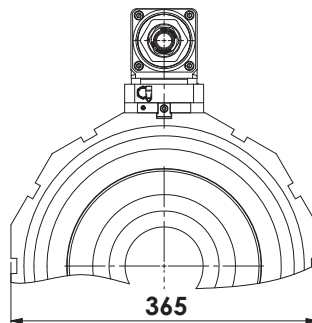

17	LT-A BMT65 ER32 LR RF 2:1 H72	NEW	05304400-R011
16	LT-A BMT65 C4 LR RF H-PR H100		05304300-R011
15	LT-A BMT65 HSK63 LR RF H72		05303300-R011
15	LT-A BMT65 HSK40 LR RF H72		05303600-R011
14	LT-S BMT65 HSK63 RF H88		05303400-R011
13	LT-A ST65 BMT65 C16 CR-AY H110		05304000-R011
13	LT-A ST65 BMT65 C16 H110		05122800-R012
13	LT-A ST35 BMT65 C12 CR-AY H100		05303800-R011
13	LT-A ST35 BMT65 C12 H100		05303700-R011
12	LT-S BMT65ER20F OF78 1:3KRH100		05303500-R011
11	LT-A BMT65 ER32F-32F H110 K-W		05101200-R011
11	LT-A BMT65 ER32F-32F H90 K-W		05101100-R011
11	LT-A BMT65 ER32F-32F H72 K-W		05101000-R011
10	LT-S2 BMT65 ER20F-20F H105X2DW		05122700-R011
9	LT-S BMT65 ER32F OFS76 RF H106		05129800-R011
8	LT-T BMT65 ER20F H71-151 G HK		05133000-R011
8	LT-T BMT65 ER16-F H63-132 K-W		05102000-R011
7	LT-A BMT65 ER25FRFOFS1:1.75H78		05129900-R011
7	LT-A BMT65 ER32F RF OFS H86 DW		05122000-R011
7	LT-A BMT65 ER32F OFS H86 DW		05122100-R011
6	LT-A BMT65 ISO-BT40 LR RF H82		05304200-R011
6	LT-A BMT65 ISO-BT40 LR H82		05304100-R011
5	LT-A BMT65 DIN-138-27 L-R H72		05129700-R011
5	LTA BMT65 DIN-22 L-R H110 K-W		05100800-R011
5	LT-A BMT65 DIN-22 L-R H90 K-W		05100600-R011
5	LT-A BMT65 DIN-22 L-R H72 K-W		05100400-R011
4	LT-A BMT65 ER32F LR RF H110		05303900-R011
4	LT-A BMT65 ER32F LR H110		05100700-R011
4	LT-A BMT65 ER32-F L-R H100		05303200-R011
4	LT-A BMT65 ER32-F L-R H90 K-W		05100500-R011
4	LT-A BMT65 ER32F LR RF H72		05122200-R011
4	LT-A BMT65 ER32-F L-R H72 K-W		05100200-R011
3	LT-S BMT65 DIN138-22 H46 K-W		05100300-R011
2	LT-S BMT65 ER40F RF H70 DW		05123000-R011
2	LT-S BMT65 ER40F H70 DW		05121900-R011
2	LT-S BMT65 ER32F RF H60 DW		05121700-R011
2	LT-S BMT65 ER32F H60 DW		05121600-R011
1	LT-S BMT65 ER32 H64 K-W		05100100-R011
Pos	Descrizione	Note	Codice

SMW AUTOBLOK GROUP

PROPRIETA' RISERVATA - Il presente disegno e' di proprieta' della MARIO PINTO SpA e non potra' essere comunicato a terzi o riprodotto in tutto o in parte senza il consenso scritto della stessa.

NOTICE - This drawing is property of MARIO PINTO SpA ITALY and shall not be reproduced, duplicated or copied in whole or in part, nor shall it be released to others without the written permission of the owner.

Diese Zeichnung darf ohne schriftliche Genehmigung von MARIO PINTO SpA ITALIEN weder kopiert noch dritten Personen mitgeteilt werden

MARIO PINTO TORINO MARIO PINTO S.p.A.	PORTAUTENSILI PER TORRETTE MOTORIZZATE		BMT				
SCALE/SCALA	DATE/DATE	DRAWN BY/DISEGN.	CHECKED/VISTO	N.	REVISED/MODIFICA	DATA	FIRMA
	03-04-2015	D. JALLIN					
WEIGHT/PESO		THE COMPANY GUAROS ITS DRAWINGS ACCORDING TO THE LAW		ASSEMBLY/COMPLESS.		DRAWING/DISEGNO	
						5010 8413.	

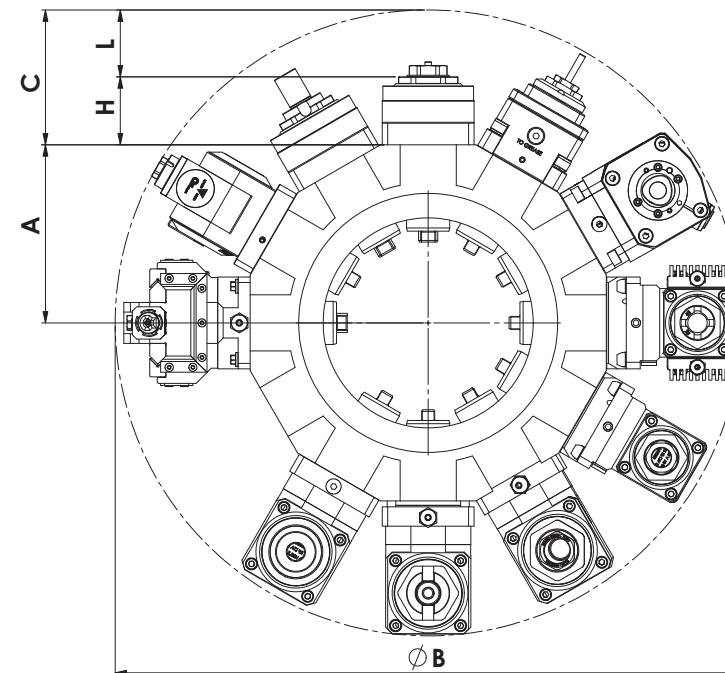
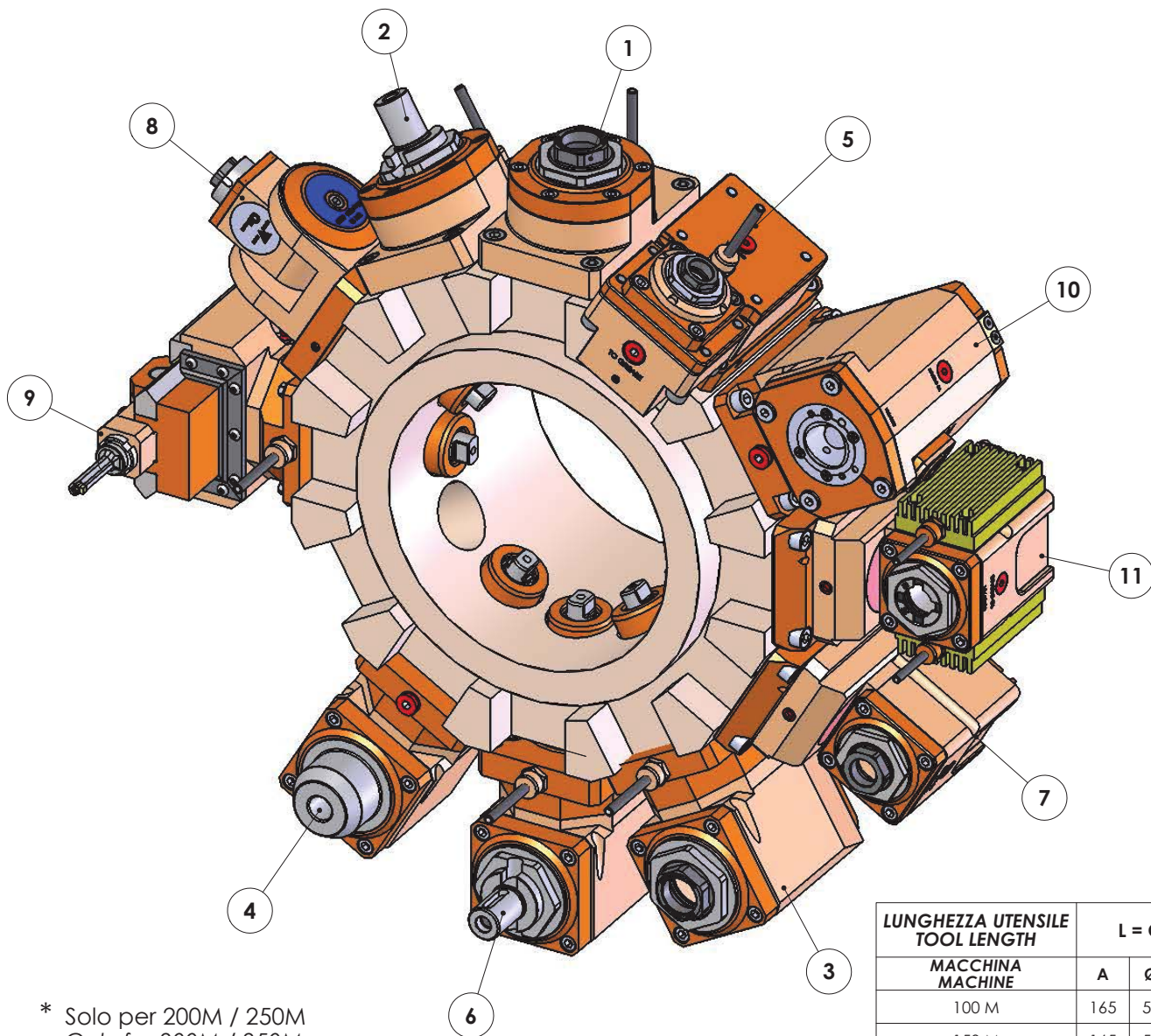

Pos	Descrizione	Note	Codice
11	LT-AOFS1:1.75D68ER25FKRH84.5MZ	NEW	05350400-R011
10	LT-A D68 C4 RFH-PR H80 MZ	NEW	05359700-R011
9	LT-A ST65 D68 C16CR-AY H104 MZ	*	05359800-R011
9	LT-A ST35 D68 C12 CR-AY H94 MZ		05351500-R011
8	LT-T D68 ER16F H56-125 MZ		05351400-R011
7	LT-AD68ER25FRFOFS1:1.75H84.5MZ		05351300-R011
6	LT-A D68 DIN138-22 H80 MZ		05351200-R011
5	LT-S D68 ER20F OFS78 1:3 H90 MZ		05350300-R011
4	LT-A D68 WELDON-16 RF H80 MZ		05350900-R011
4	LT-A D68 WELDON-16 H80 MZ		05351000-R011
4	LT-A D68 WELDON-12 H80 MZ		05351100-R011
3	LT-A D68 ER32F RF H80 MZ		05350500-R011
3	LT-A D68 ER32F H80 MZ		05350600-R011
2	LT-S D68 DIN138-22 H70 MZ		05350200-R011
1	LT-S D68 ER32F RF H63 MZ		05350000-R011
1	LT-S D68 ER32F H63 MZ		05350100-R011

LUNGHEZZA UTENSILE TOOL LENGTH	L = C - H		
	A	ØB	C
MACCHINA MACHINE			
100 M	165	564	117
150 M	165	564	117
200 M	165	580	125
250 M	165	600	135

* Solo per 200M / 250M
Only for 200M / 250M

SMW AUTOBLOK GROUP			
PROPRIETA' RISERVATA - Il presente disegno e' di proprieta' della MARIO PINTO SpA e non potra' essere comunicato a terzi o riprodotto in tutto o in parte senza il consenso scritto della stessa.		NOTICE - This drawing is property of MARIO PINTO SpA ITALY and shall not be reproduced, duplicated or copied in whole or in part, nor shall it be released to others without the written permission of the owner.	
Diese Zeichnung darf ohne schriftliche Genehmigung von MARIO PINTO SpA ITALIEN weder kopiert noch dritten Personen mitgeteilt werden			
MARIO PINTO S.p.A. TORINO	PORTAUTENSILI PER TORRETTE MOTORIZZATE	MAZAK	
SCALE/SCALA: _____ DATE/DATE: 04-07-2014 DRAWN BY/DISEGN: JANNUZZI CHECKED/VISTO: _____	N. _____ REVISOR/MODIFICA: _____ DATA: 7/04/2015 FIRMA: _____	ASSEMBLY/COMPLESS: _____ DRAWING/DISEGNO: 5010 8545 -1	

TORRETTE SUPERIORI SINISTRA E DESTRA UPPER TURRETS LEFT AND RIGHT

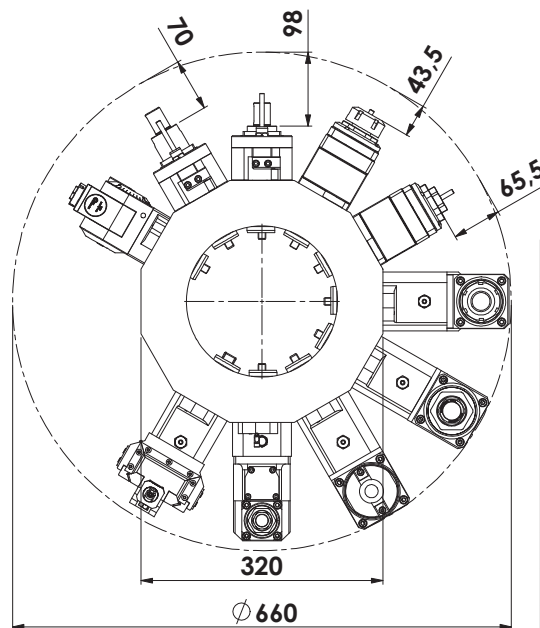
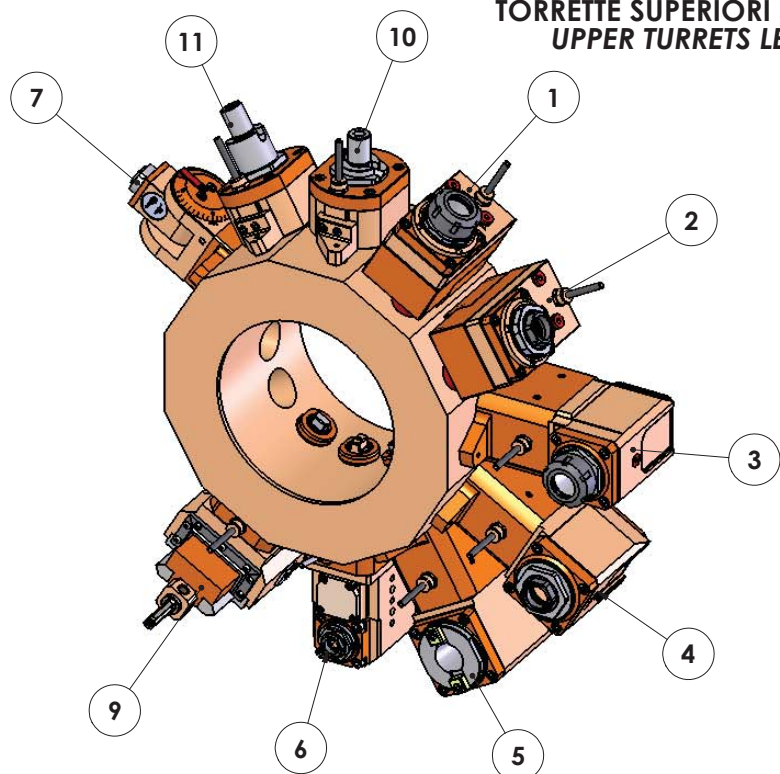

TORRETTA INFERIORE LOWER TURRET

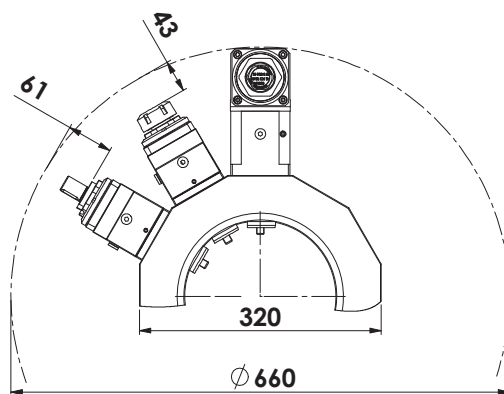
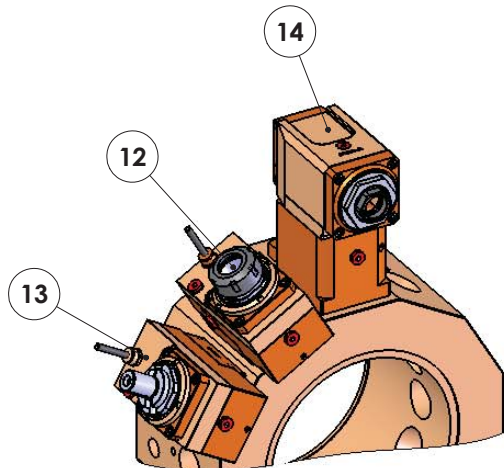

14	LT-A VDI40 ER32F RF H130 MZ	NEW	05355400-R011
13	LT-S VDI40 DIN22 OFS50 H110 MZ	NEW	05355100-R011
12	LT-S VDI40 ER32 RFOFS-50H127MZ		05258300-R011
12	LT-S VDI40 ER32 OFS-50 H127 MZ		05258200-R011
11	LT-S VDI40 DIN138-22 H100 MZ	NEW	05355300-R011
10	LT-S VDI40 DIN138-22 H72 MZ	NEW	05355200-R011
9	LT-A ST35 VDI40 C12 H135 MZ		05259100-R011
7	LT-T VDI40 ER16F H113-182 MZ	NEW	05259200-R011
7	LT-T VDI40 ER20F H71-151 MZ		05052900-R011
7	LT-T VDI40 ER16F H63-132 MZ		05052200-R012
6	LT-A VDI40 ER20F H130 1:2 MZ		05052700_R011
5	LT-A VDI40 ISO-BT30 H130 MZ		05052400-R011
4	LT-A VDI40 ER32F RF H130 MZ		05052600-R011
4	LT-A VDI40 ER32F H130 MZ		05052500-R011
3	LT-A VDI40 ER32 L-R H130 MZ		05052100-R011
2	LT-S VDI40ER32FRFOFS50 H104 MZ		05259000-R011
2	LT-S VDI40 ER32F OFS50 H104 MZ		05052800-R011
1	LT-S VDI40 ER32 OFS50 H117 MZ		05052000-R011
Pos	Descrizione	Note	Codice

SMW AUTOBLOK GROUP

PROPRIETA' RISERVATA - Il presente disegno e' di proprieta' della MARIO PINTO SpA e non potra' essere comunicato a terzi o riprodotto in tutto o in parte senza il consenso scritto della stessa.

NOTICE - This drawing is property of MARIO PINTO SpA ITALY and shall not be reproduced, duplicated or copied in whole or in part, nor shall it be released to others without the written permission of the owner.

Diese Zeichnung darf ohne schriftliche Genehmigung von MARIO PINTO SpA ITALIEN weder kopiert noch dritten Personen mitgeteilt werden

		PORTAUTENSILI PER TORRETTE MOTORIZZATE		MAZAK	
SCALE/SCALA	DATE/DATE	DRAWN BY/DISEGN.	CHECKED/VISTO	N.	REVISI/MODIFICA
	19-12-2013	D. JALLIN			
		WEIGHT/PESO	THE COMPANY GUARDS ITS DRAWINGS ACCORDING TO THE LAW		DATA FIRMA
		Machined ES/DE			ASSEMBLY/COMPLESS. DRAWING/DISEGNO
					5010 8571

VDI - 40

MANDRINO PRINCIPALE
MAIN SPINDLE
CABEZAL PRINCIPAL
HAUPTSPINDEL
主軸
ГЛАВНЫЙ ШПИНДЕЛЬ

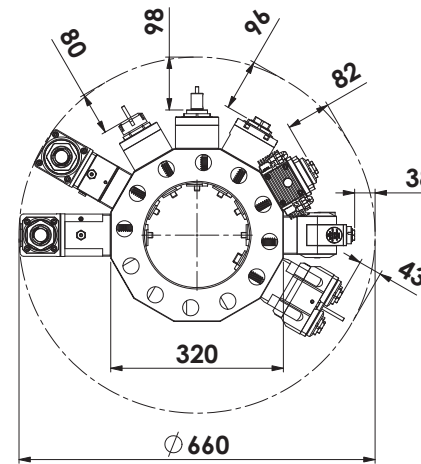
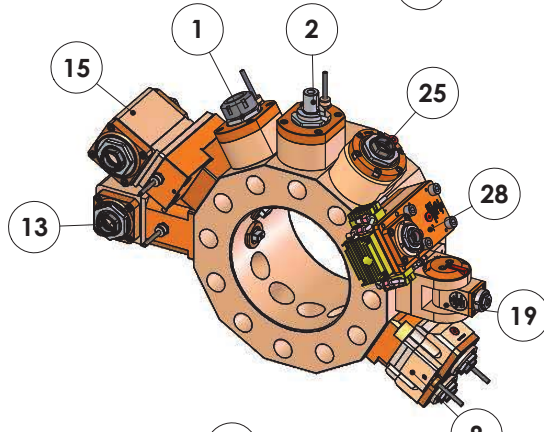
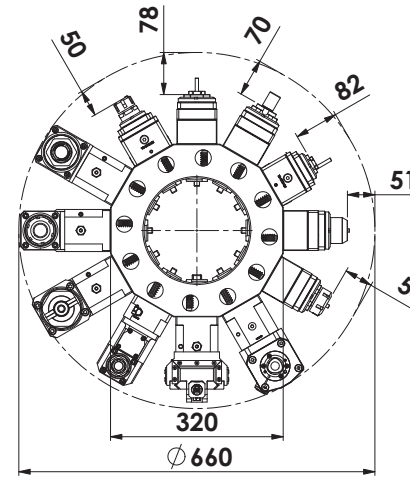
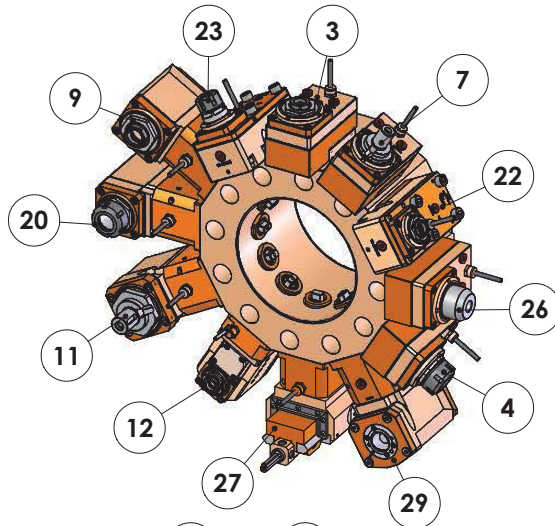

MANDRINO SECONDARIO
SECONDARY SPINDLE
CABEZAL SECUNDARIO
GEGENSPINDEL
第2主軸
ДОПОЛНИТЕЛЬНЫЙ ШПИНДЕЛЬ

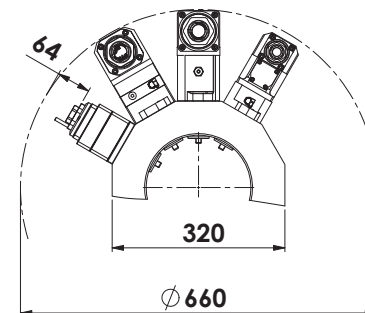
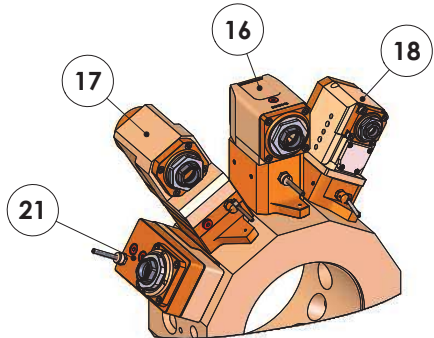

Pos	Descrizione	Note	Codice
29	LT-A VDI40 C4 RFH-PR H130 MZ	NEW	05353400-R011
28	LT-SVDI40ER20F0FS78 1:3KRH89MZ		05353300-R011
27	LT-A ST35VDI40 C12CR-AY H135MZ	NEW	05353800-R011
27	LT-A ST35 VDI40 C12 H135 MZ		05353200-R011
26	LT-S VDI40 WELD16 OFS50 H119MZ		05353100-R011
25	LT-S VDI40 ER32F RF H74 MZ		05251800-R011
23	LTS VDI40 ER20 OFS78 1:3H120MZ		05257000-R011
22	LTS VDI40 ER20F OFS78 1:3H90MZ		05256900-R011
21	LT-S VDI40 ER32F OF62 H106 MZ	NEW	05353900-R011
21	LT-S VDI40 ER25F OF62 H103 MZ		05256700-R011
20	LT-A VDI40ER32 L RFH-PR H130MZ	NEW	05353600-R011
20	LT-A VDI40 ER32 L H130 MZ		05050900-R011
19	LT-T VDI40 ER16F H113-182 MZ		05257300-R011
19	LT-T VDI40 ER16F H63-132 MZ		05051900-R011
18	LT-A VDI40 ER20F R H130 1:2 MZ		05250800-R011
17	LT-A VDI40 ER32F OF RF H130 MZ		05250400-R011
17	LT-A VDI40 ER32F R OFS H130 MZ		05058300-R011
16	LT-A VDI40 ER32F R RF H130 MZ		05053400-R011
16	LT-A VDI40 ER32F R H130 MZ		05053200-R011
16	LT-A VDI40 ER25F R H130 MZ	NEW	05354000-R011
15	LTA VDI40 ER32F-32F OF H130 MZ		05058600-R011
13	LT-A VDI40 ER32F-32F RF H130MZ		05256800-R011
13	LT-A VDI40 ER32F-32F L H130 MZ	*	05250600-R011
13	LT-A VDI40 ER32F-32F L H130 MZ		05053000-R011
12	LT-A VDI40 ER20F L H130 1:2 MZ		05250700-R011
11	LT-A VDI40 DIN138-27 L H130 MZ		05051600-R011
11	LT-A VDI40 DIN138-22 L H130 MZ		05051700-R011
9	LT-A VDI40 ER40F L RF H130 MZ		05250500-R011
9	LT-A VDI40 ER32F L RF H130 MZ		05053800-R011
9	LT-A VDI40 ER32F L H130 MZ		05058000-R011
9	LT-A VDI40 ER25F L RF H130 MZ		05250200-R011
8	LT-S2VDI40ER20F-20F H122 1:2MZ		05251500-R011
8	LT-S2VDI40ER20F-20F H122 1:1MZ		05251600-R011
7	LT-S VDI40 DIN22 OFS50 H100 MZ		05051300-R011
4	LT-SVDI40ER32OF50RFH-PR H120MZ	NEW	05353500-R011
4	LT-S VDI40 ER32 OFS50 H117 MZ		05051200-R011
3	LT-SVDI40ER32F0F50RFH-PR H97MZ	NEW	05353700-R011
3	LT-S VDI40 ER40F OFS76RFH108MZ		05256600-R011
3	LT-S VDI40 ER40F OFS76 H108 MZ		05256500-R011
3	LT-S VDI40 ER32F OF76 RF MZ		05250000-R011
3	LT-S VDI40 ER32F OFS50 H95 MZ		05250900-R011
3	LT-S VDI40 ER 25-F OFS50 H92 MZ		05250100-R011
2	LT-S VDI40 DIN138-22 H72 MZ		05058800-R011
2	LT-S VDI40 DIN138-16 H70 MZ		05250300-R011
1	LT-S VDI40 ER32 H90.5 MAZAK		05050100-R012

SMW AUTOBLOK GROUP

PROPRIETA' RISERVATA - Il presente disegno e' di proprieta' della MARIO PINTO SpA e non potra' essere comunicato a terzi o riprodotto in tutto o in parte senza il consenso scritto della stessa.

NOTICE - This drawing is property of MARIO PINTO SpA ITALY and shall not be reproduced, duplicated or copied in whole or in part, nor shall it be released to others without the written permission of the owner.

Diese Zeichnung darf ohne schriftliche Genehmigung von MARIO PINTO SpA ITALIEN weder kopiert noch dritten Personen mitgeteilt werden

MARIO PINTO TORINO MARIO PINTO S.p.A.		PORTAUTENSILI PER TORRETTE MOTORIZZATE		MAZAK	
SCALE/SCALA	DATE/DATE	DRAWN BY/DISEGN	CHECKED/VISTO	N.	REVISID/MODIFICA
	06-10-2014	IANNUZZI		enrico	29/07/2015
WEIGHT/PESO			THE COMPANY GUARDES ITS DRAWINGS ACCORDING TO THE LAW		
Raw Design			Machined Part		
			5010 8369 -1		

**TORRETTA SUPERIORE E INFERIORE
UPPER AND LOWER TURRET**

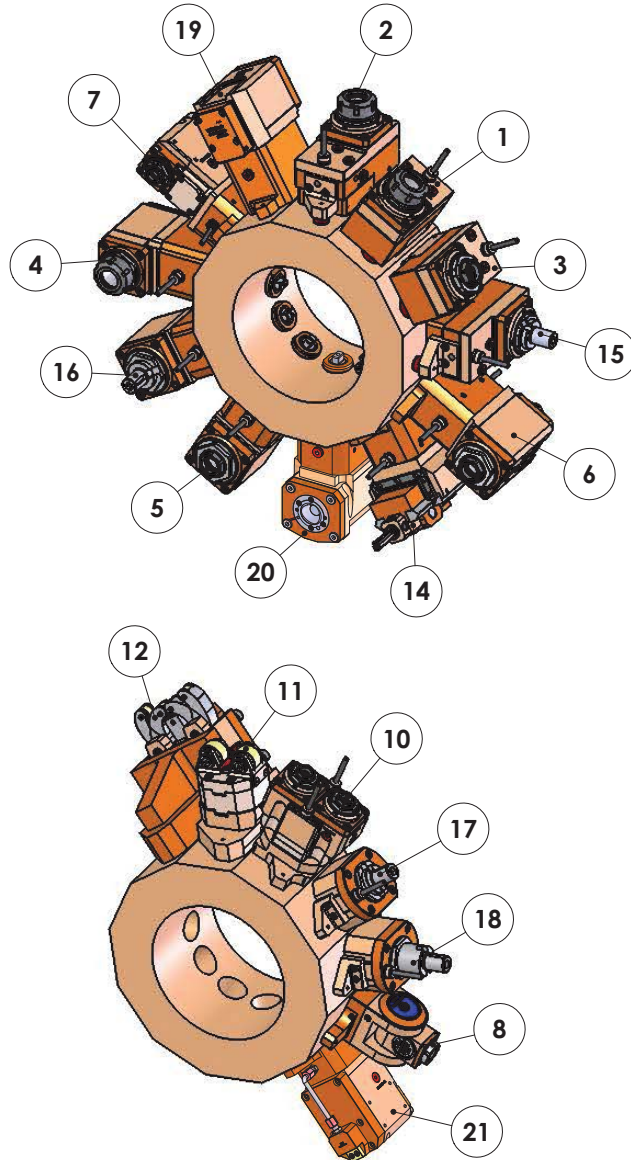

**MANDRINO PRINCIPALE E SECONDARIO
MAIN AND SECONDARY SPINDLE**

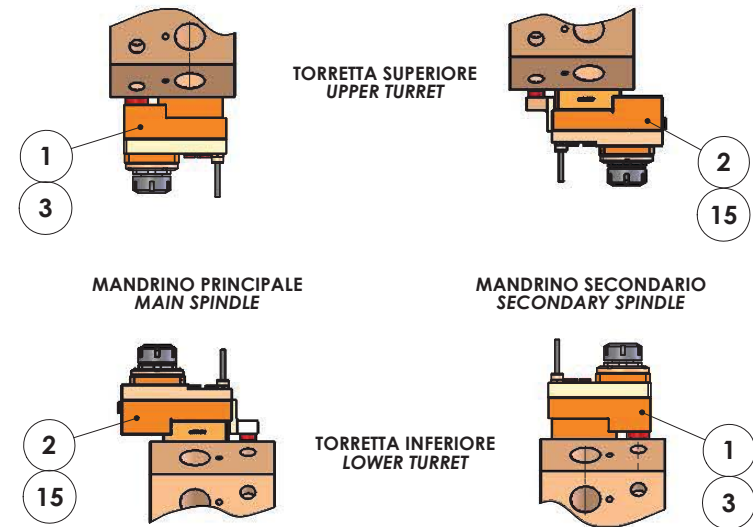
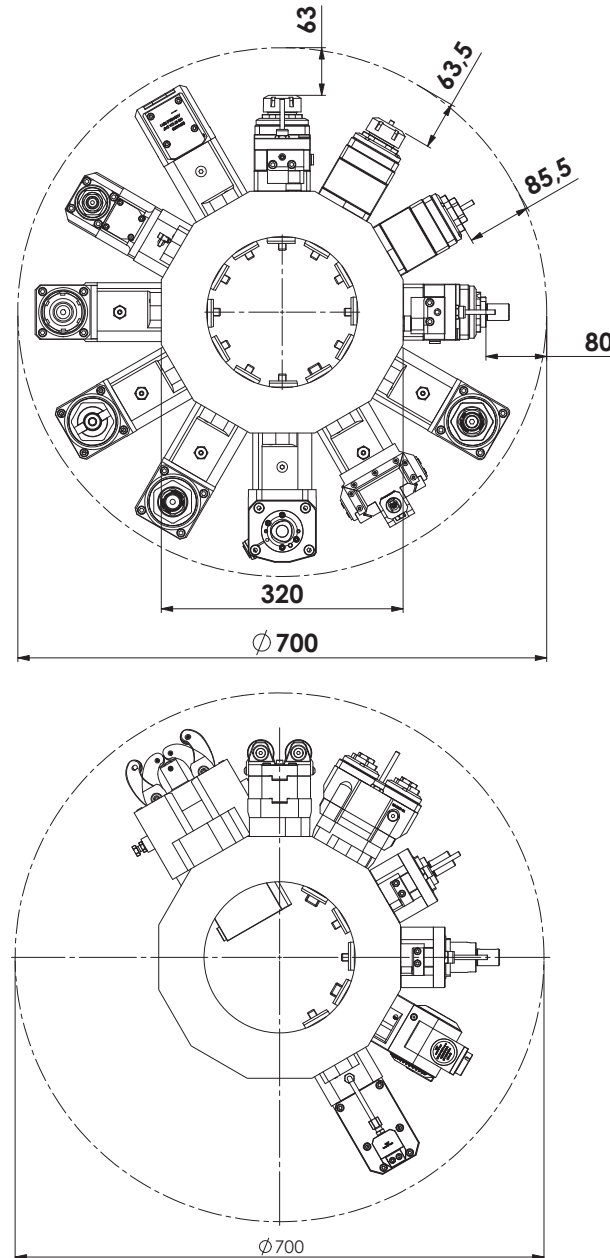

21	LT-A VDI40ER20FRFH-PRH1301:2MZ	NEW	05355600-R011
20	LT-A VDI40 C4 RFH-PR H130 MZ		05259400-R011
19	LT-A VDI40 ER32F RF H130 MZ		05355400-R011
18	LT-S VDI40 DIN138-22 H100 MZ		05355300-R011
17	LT-S VDI40 DIN138-22 H72 MZ		05355200-R011
16	LT-A VDI40 DIN138-22 H130 MZ		05355000-R011
15	LT-S VDI40 DIN22 OFS50 H110 MZ		05355100-R011
14	LT-A ST35 VDI40 C12 H135 MZ		05259100-R011
12	LUNETTA H140 HYPER Q.200 MZ		05258900-R011
11	SUPP.ALB AX 20-100 HYPER-Q.200		05258800-R011
10	LT-S2VDI40ER20F-20FH1221:1Q2MZ		05258100-R011
8	LT-T VDI40 ER20F H132-212 MZ		05258700-R011
8	LT-T VDI40 ER20F H71-151 MZ		05052900-R011
8	LT-T VDI40 ER16F H63-132 MZ		05052200-R012
7	LT-A VDI40ER20FRFH-PRH1301:2MZ	NEW	05355500-R011
7	LT-A VDI40 ER20F H130 1:2 MZ		05052700-R011
6	LT-A VDI40 ER32F-32F H130 Q2MZ		05258000-R011
5	LT-A VDI40 ER32F RF H130 MZ		05052600-R011
5	LT-A VDI40 ER32F H130 MZ		05052500-R011
4	LT-A VDI40 ER32 L-R H130 MZ		05052100-R011
3	LT-S VDI40ER32FRFOFS50 H104 MZ		05259000-R011
3	LT-S VDI40 ER32F OFS50 H104 MZ		05052800-R011
2	LT-S VDI40 ER32 RFOFS-50H127MZ		05258300-R011
2	LT-S VDI40 ER32 OFS-50 H127 MZ		05258200-R011
1	LT-S VDI40 ER32 OFS50 H117 MZ		05052000-R011
Pos	Descrizione	Note	Num. parte

SMW AUTOBLOK GROUP

PROPRIETA' RISERVATA - Il presente disegno e' di proprieta' della MARIO PINTO SpA e non potra' essere comunicato a terzi o riprodotto in tutto o in parte senza il consenso scritto della stessa.

NOTICE - This drawing is property of MARIO PINTO SpA ITALY and shall not be reproduced, duplicated or copied in whole or in part, nor shall it be released to others without the written permission of the owner.

Diese Zeichnung darf ohne schriftliche Genehmigung von MARIO PINTO SpA ITALIEN weder kopiert noch dritten Personen mitgeteilt werden

MARIO PINTO TORINO MARIO PINTO S.p.A.				PORTAUTENSILI PER TORRETTE MOTORIZZATE		MAZAK	
SCALE/SCALA	DATE/DATE	DRAWN BY/DESIGN	CHECKED/VISTO	N.	REVISED/MODIFICA	DATA	FIRMA
	17-03-2015	D. JALLIN		lanuzzi		7/04/2015	
WEIGHT/PESO				ASSEMBLY/COMPLESS		DRAWING/DESIGNO	
Raw				Machine		5010 8534 -1	
The company guards its drawings according to the law							

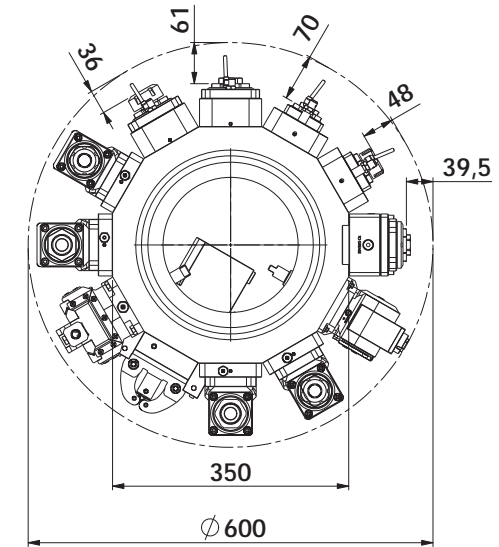
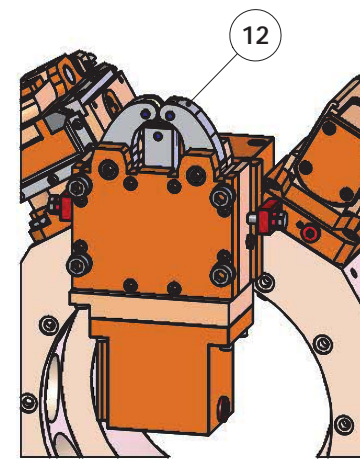
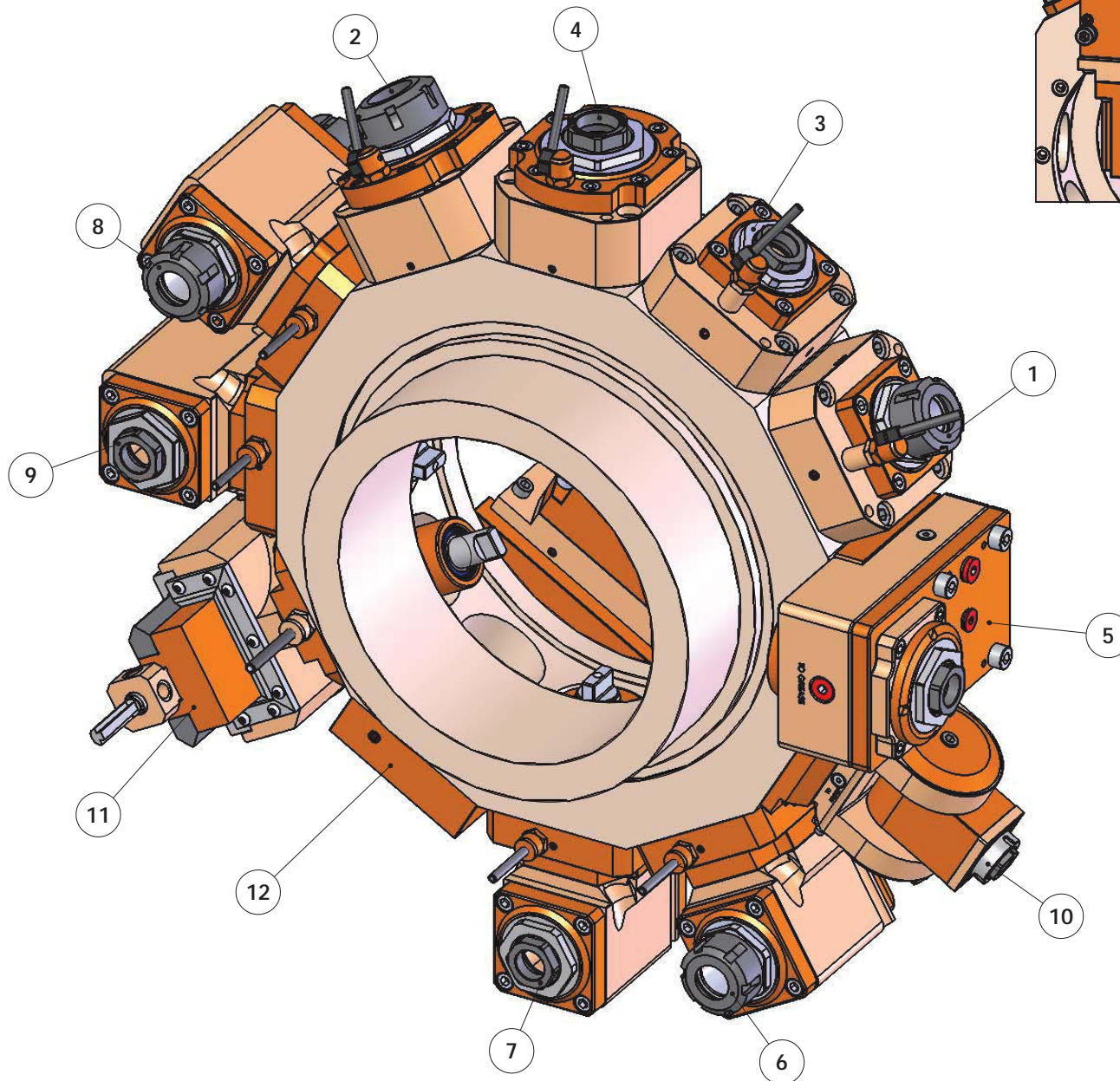

12	LUNETTA H87 D54 MY		05282600-R011
11	LT-A ST35 D54 C12 H90 MY		05282400-R011
10	LT-T D54 ER16F H58-124 MY		05282100-R011
9	LT-A D54 ER25F-25F H75 MY		05282200-R011
8	LT-A D54 ER25-25 H75 MY		05282500-R011
7	LT-A D54 ER32F HRF 2:1 H75 MY	NEW	05282800-R011
7	LT-A D54 ER32F RF H-PR H75 MY		05282700-R011
7	LT-A D54 ER32F RF H75 MY		05281900-R011
7	LT-A D54 ER32F H75 MY		05282000-R011
7	LT-A D54 ER25F RF H75 MY		05281100-R011
7	LT-A D54 ER25F H75 MY		05281200-R011
6	LT-A D54 ER32 RF H75 MY		05281800-R011
6	LT-A D54 ER32 H75 MY		05281700-R011
6	LT-A D54 ER25 RF H75 MY		05280900-R011
6	LT-A D54 ER25 H75 MY		05281000-R011
5	LT-S D54 ER25F OFS72 RF H85 MY		05282300-R011
4	LT-S D54 ER32F RF H64 MY		05281500-R011
4	LT-S D54 ER32F H64 MY		05281600-R011
3	LT-S D54 ER25F RF H55 MY		05280300-R011
3	LT-S D54 ER25F H55 MY		05280400-R011
2	LT-S D54 ER32 RF H89 MY		05281300-R011
2	LT-S D54 ER32 H89 MY		05281400-R011
1	LT-S D54 ER25 RF H77 MY		05280100-R011
1	LT-S D54 ER25 H77 MY		05280200-R011
Pos	Descrizione	Note	Codice

SMW AUTOBLOK GROUP

PROPRIETA' RISERVATA - Il presente disegno e' di proprieta' della MARIO PINTO SpA e non potra' essere comunicato a terzi o riprodotto in tutto o in parte senza il consenso scritto della stessa.

NOTICE - This drawing is property of MARIO PINTO SpA ITALY and shall not be reproduced, duplicated or copied in whole or in part, nor shall it be released to others without the written permission of the owner.

Diese Zeichnung darf ohne schriftliche Genehmigung von MARIO PINTO SpA ITALIEN weder kopiert noch dritten Personen mitgeteilt werden

		PORTAUTENSILI PER TORRETTE MOTORIZZATE		MIYANO	
SCALE/SCALA	DATE/DATA	DRAWN BY/DISEGN	CHECKED/VISTO	N.	REVISED/MODIFICA
	18-05-2015	IANNUZZI			DATA
WEIGHT/PESO			ASSEMBLY/COMPLESS		
Machined			THE COMPANY GUARANTIES ITS DRAWINGS ACCORDING TO THE LAW		
			5010 8544		

D-40

MANDRINO PRINCIPALE E SECONDARIO
MAIN AND SECONDARY SPINDLE
CABEZAL PRINCIPAL Y SECUNDARIO
HAUPTSPINDEL / GEGENSPINDEL
主軸および第2の軸
главный и дополнительный
шпиндель

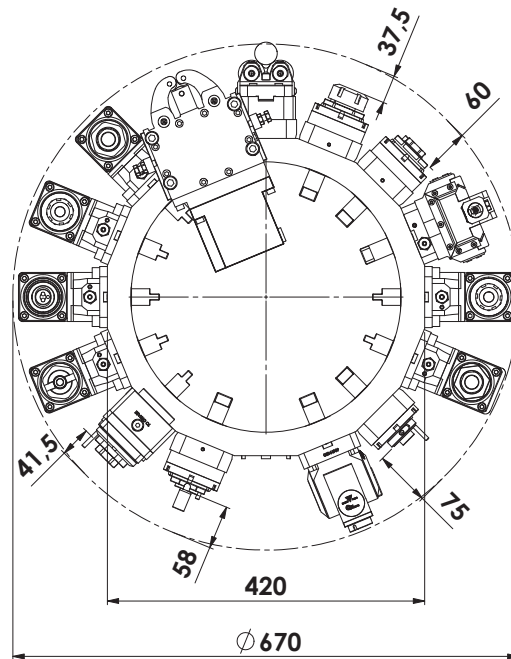
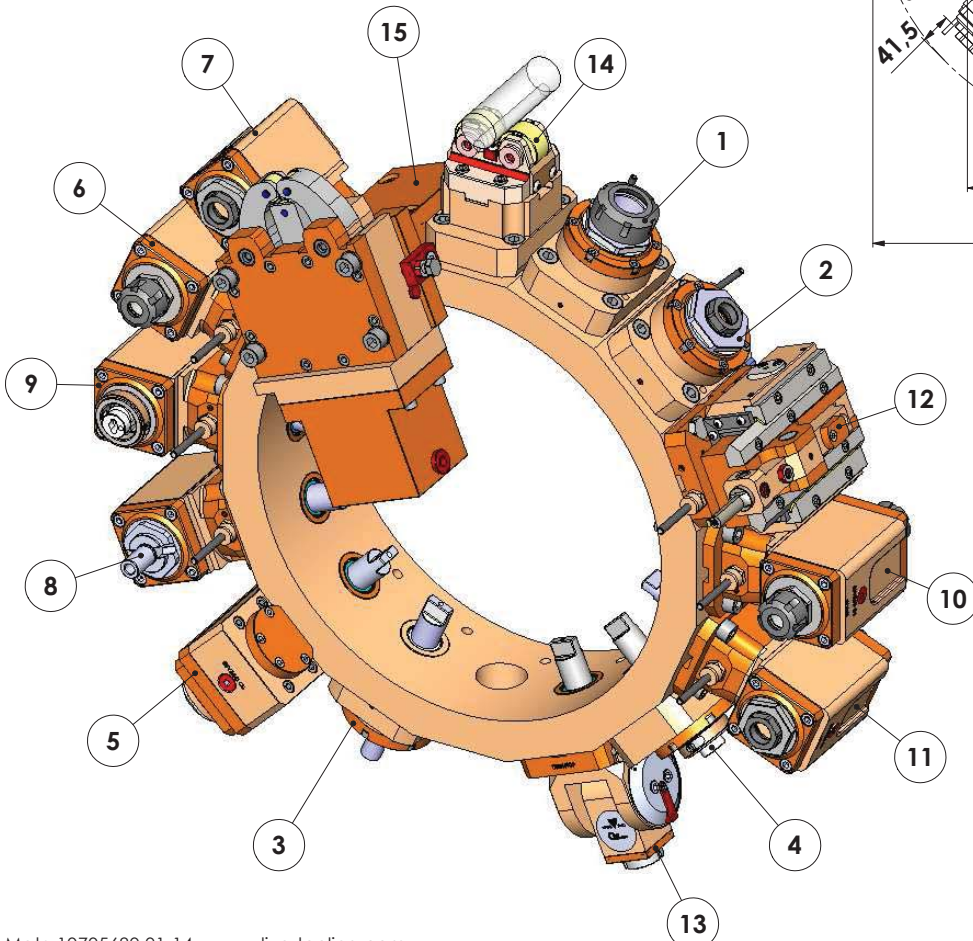

15	LUNETTA H93 D40 MS		05247000-R011
14	SUPP ALB AX D10-30 D40 MS		05246900-R011
13	LT-T D40 ER16F LR H63-120 MS		05244900-R011
12	LT-A ST35 D40 C12 CR-AY H90 MS	NEW	05247100-R011
12	LT-A ST35 D40 C12 H90 MS		05245900-R011
11	LT-A D40 ER25F-25F 2:1 H85 MS		05245800-R011
11	LT-A D40 ER25F-25F H85 MS		05245400-R011
10	LT-A D40 ER20-20 H85 MS		05244200-R011
9	LT-A D40 HSK-40 RF H85 MS		05246400-R011
9	LT-A D40 HSK-40 H85 MS		05246300-R011
8	LT-A D40 DIN138-22 H85 MS		05246800-R011
8	LT-A D40 DIN138-16 H85 MS		05246700-R011
7	LT-A D40 ER25F RF H85 MS		05245300-R011
7	LT-A D40 ER25F H85 MS		05245200-R011
6	LT-A D40 ER20 H85 MS		05244100-R011
5	LT-S D40 ER32F OFS90 RF H84 MS		05246000-R011
5	LT-S D40 ER32F OFS90 H84 MS		05246500-R011
5	LT-S D40 ER25F OFS90 RF H82 MS		05246100-R011
5	LT-S D40 ER25F OFS90 H82 MS		05246600-R011
4	LT-S D40 HSK40 H50 MS		05246200-R011
3	LT-S D40 DIN138-22 H70 MS		05244800-R011
3	LT-S D40 DIN138-16 H67 MS		05244700-R011
2	LT-S D40 ER32F RF H70 MS		05244600-R011
2	LT-S D40 ER32F H70 MS		05244500-R011
2	LT-S D40 ER25F RF H65 MS		05244400-R011
2	LT-S D40 ER25F H65 MS		05244300-R011
1	LT-S D40 ER32 RF H87 MS		05245000-R011
1	LT-S D40 ER32 H87 MS		05245100-R011
1	LT-S D40 ER25 RF H84 MS		05245500-R011
1	LT-S D40 ER25 H84 MS		05245600-R011
1	LT-S D40 ER20 RF H90 MS		05245700-R011
1	LT-S D40 ER20 H90 MS		05244000-R011
Pos	Descrizione	Note	Codice

SMW AUTOBLOK GROUP

PROPRIETA' RISERVATA - Il presente disegno e' di proprieta' della MARIO PINTO SpA e non potra' essere comunicato a terzi o riprodotto in tutto o in parte senza il consenso scritto della stessa.

NOTICE - This drawing is property of MARIO PINTO SpA ITALY and shall not be reproduced, duplicated or copied in whole or in part, nor shall it be released to others without the written permission of the owner.

Diese Zeichnung darf ohne schriftliche Genehmigung von MARIO PINTO SpA ITALIEN weder kopiert noch dritten Personen mitgeteilt werden

MARIO PINTO TORINO MARIO PINTO S.p.A.	PORTAUTENSILI PER TORRETTE MOTORIZZATE	MORI SEIKI	
SCALE/SCALA	DATE/DATA 17-03-2015	DRAWN BY/DISEGN. IANNUZZI	CHECKED/VISTO
WEIGHT/PESO	Raw/Disegno	Machined/Disegno	THE COMPANY GUARDES ITS DRAWINGS ACCORDING TO THE LAW
ASSEMBLY/COMPLESS.		DRAWING/DISEGNO	
-		5010 8517	

**MANDRINO PRINCIPALE E SECONDARIO
 MAIN AND SECONDARY SPINDLE
 CABEZAL PRINCIPAL Y SECUNDARIO
 HAUPTSPINDEL / GEGENSPINDEL
 主軸および第2の軸
 ГЛАВНЫЙ И ДОПОЛНИТЕЛЬНЫЙ
 ШПИНДЕЛЬ**

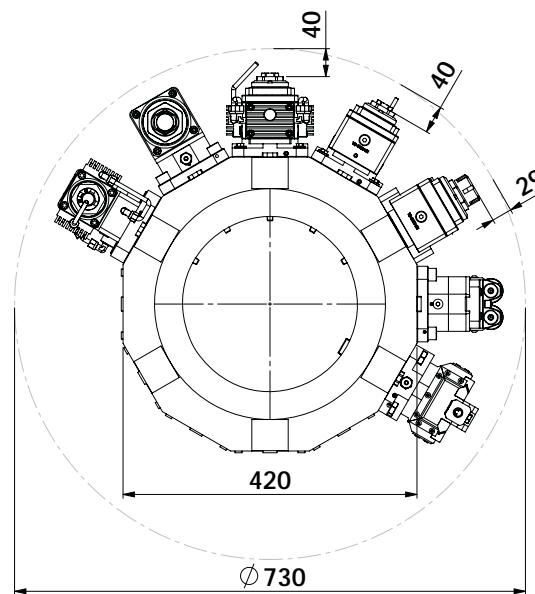
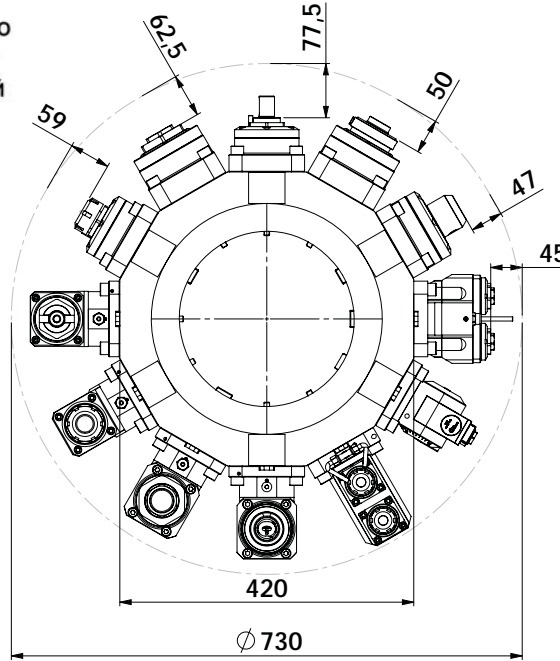
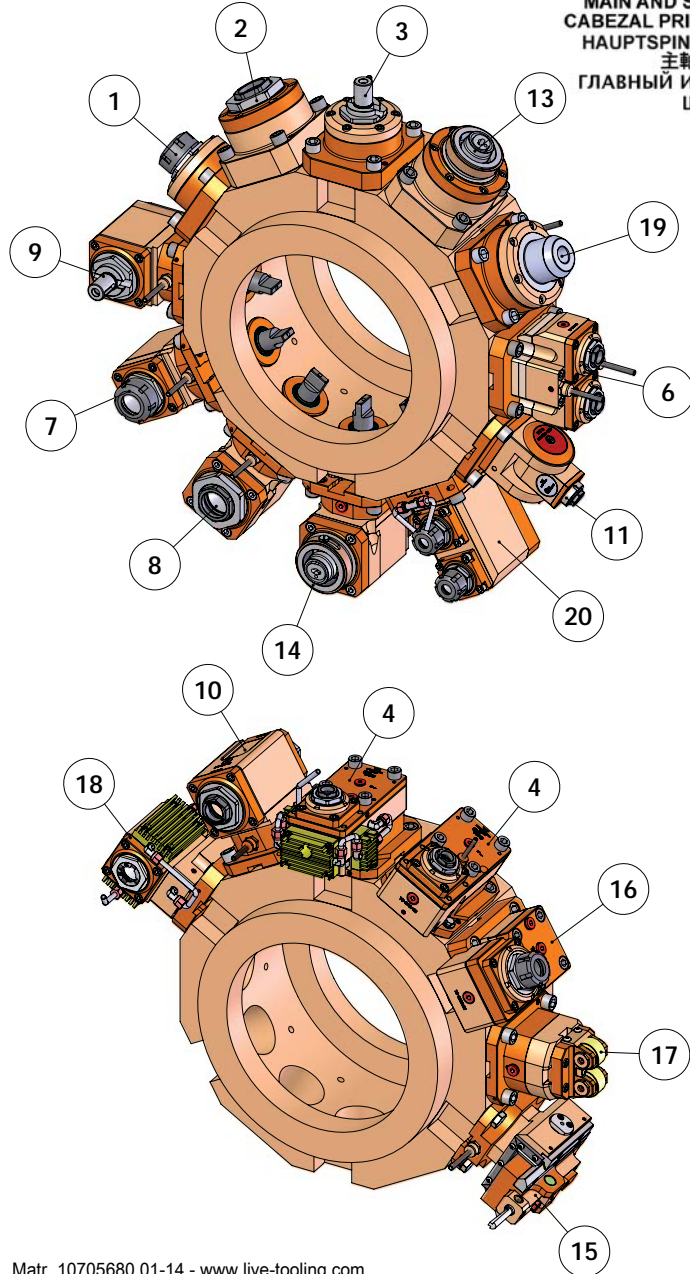

20	LT-A2V D60 ER20-20 LR OFS63 MS		05240300-R011
19	LT-S D60 WELDON 20 MS		05049900-R011
18	LT-A D60ER25F-25FKROFS 1:2 MS		05048800-R011
17	SUPP ALB AX D50-150 D60 MS	NEW	05048500-R011
17	SUPP ALB AX D10-30 D60 MS		05049400-R011
16	LT-S D60 ER32 OF76RF 1:1H130MS		05049200-R011
16	LT-S D60 ER25 OF76RF 1:1H126MS		05049300-R011
15	LT-A ST65 D60 C16 H110 MS		05049800-R011
15	LT-A ST35 D60 C12 H100 MS		05047100-R011
14	LT-A D60 HSK-63 LR RF H90 MS		05046700-R011
14	LT-A D60 HSK-40 LR RF H90 MS		05046900-R011
13	LT-S D60 HSK-63 RF H105 MS		05046600-R011
13	LT-S D60 HSK-40 RF H97 MS		05046800-R011
11	LT-T D60 ER20F H70-151 MS		05041700-R011
11	LT-T D60 ER16F H63-132 MS		05041600-R011
10	LT-A D60 ER32F-32F LR2:1H90 MS		05046500-R011
10	LT-A D60 ER32F-32F LR RF H90MS		05049700-R011
10	LT-A D60 ER32F-32F L-R H90 MS		05041400-R011
9	LT-A D60 DIN138-27 L-R H90 MS		05041200-R011
9	LT-A D60 DIN138-22 L-R H90 MS		05041300-R011
8	LT-A D60 ER40F LR RF H90 MS		05040700-R011
8	LT-A D60 ER40-F L-R H90 MS		05041000-R011
8	LT-A D60 ER32F LR RF H90 MS		05047400-R011
7	LT-A D60 ER32 LR RF H-PR H90MS		05240200-R011
7	LT-A D60 ER40 L-R 2:1 H90 MS		05049600-R011
7	LT-A D60 ER40 LR RF H90 MS		05049100-R011
7	LT-A D60 ER40 L-R H90 MS		05040600-R011
7	LT-A D60 ER32 LR RF H90 MS		05049000-R011
7	LT-A D60 ER32 L-R H90 MS		05040100-R011
6	LT-S2 D60 ER20F-20F H111 1:2MS		05042000-R011
6	LT-S2 D60 ER20F-20F H111 1:1MS		05042300-R011
4	LT-S D60ER32FOFS0RFH-PRH102MS		05240100-R011
4	LT-S D60 ER40F OFS95RF2:1H108MS		05042200-R011
4	LT-S D60 ER40F OFS95 2:1H108MS		05042100-R011
4	LT-S D60 ER32F OF76RF1:1H106MS		05047200-R011
4	LT-S D60 ER25F OF76RF1:1H104MS		05047300-R011
4	LT-S D60ER20FOF78LR1:3KR H115MS		05049500-R011
4	LT-S D60 ER20F OF78LR1:3H115MS		05041800-R011
3	LT-S D60 DIN138-27 H79 MS		05040500-R011
3	LT-S D60 DIN138-22 H77 MS		05040400-R011
2	LT-S D60 ER40F RF H93 MS		05041100-R011
2	LT-S D60 ER32F RF H90 MS		05048400-R011
1	LT-S D60 ER40 H90 MS		05040300-R011
1	LT-S D60 ER32 H96 MS		05040200-R011
Pos	Descrizione	Note	Num. parte

SMW AUTOBLOK GROUP

PROPRIETA' RISERVATA - Il presente disegno e' di proprieta' della MARIO PINTO SpA e non potra' essere comunicato a terzi o riprodotto in tutto o in parte senza il consenso scritto della stessa.

NOTICE - This drawing is property of MARIO PINTO SpA ITALY and shall not be reproduced, duplicated or copied in whole or in part, nor shall it be released to others without the written permission of the owner.

Diese Zeichnung darf ohne schriftliche Genehmigung von MARIO PINTO SpA ITALIEN weder kopiert noch dritten Personen mitgeteilt werden

MARIO PINTO TORINO MARIO PINTO S.p.A.		PORTAUTENSILI PER TORRETTE MOTORIZZATE		MORI SEIKI	
SCALE/SCALA	DATE/DATE	DRAWN BY/DISEGN.	CHECKED/VISTO	N.	REVISED/MODIFICA
	03-03-2015	D. JALLIN			03/07/2015
				ASSEMBLY/COMPLEX.	DRAWING/DISEGNO
		WEIGHT/PESO	THE COMPANY GUARDS ITS DRAWINGS ACCORDING TO THE LAW		5010 8366
		Raw Crash	Machined Etch		

MANDRINO PRINCIPALE E SECONDARIO
MAIN AND SECONDARY SPINDLE
CABEZAL PRINCIPAL Y SECUNDARIO
HAUPTSPINDEL / GEGENSPINDEL
 主軸および第2の軸
ГЛАВНЫЙ И ДОПОЛНИТЕЛЬНЫЙ ШПИНДЕЛЬ

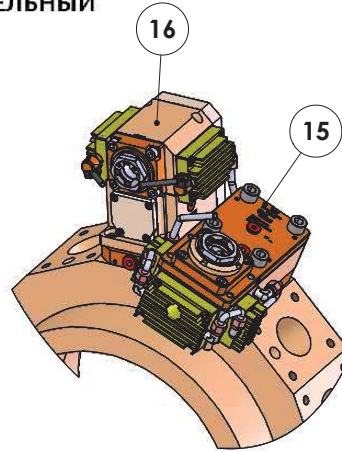
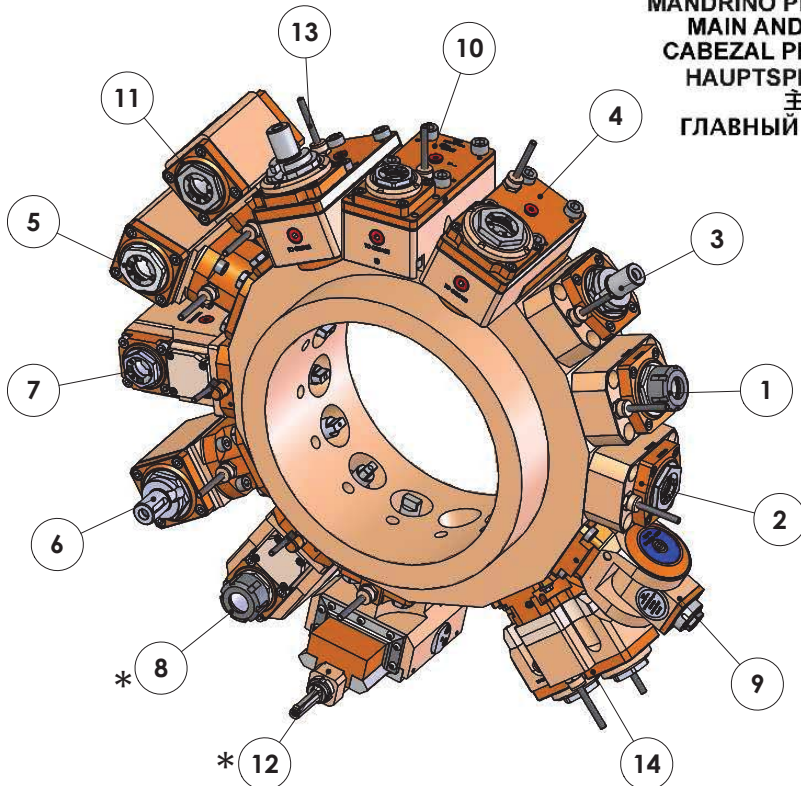

LUNGHEZZA UTENSILE TOOL LENGTH		L = C - H		
MACCHINA	A	ØB	C	
MT 12	190	670	145	
MT 200	190	710	165	
MT 200 LOWER TURRET	165	620	145	

TORRETTA INFERIORE
LOWER TURRET
TORRETA INFERIOR
UNTERER REVOLVER
 下部タレット
НИЖНЯЯ РЕВОЛЬВЕРНАЯ ГОЛОВКА

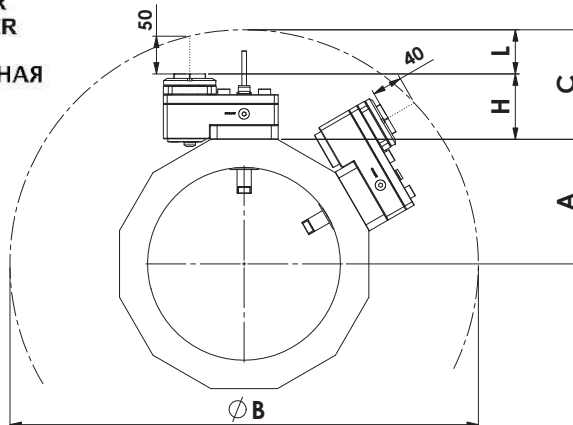
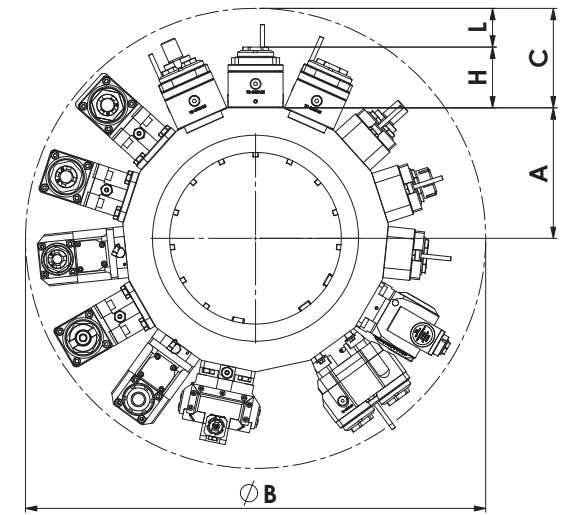
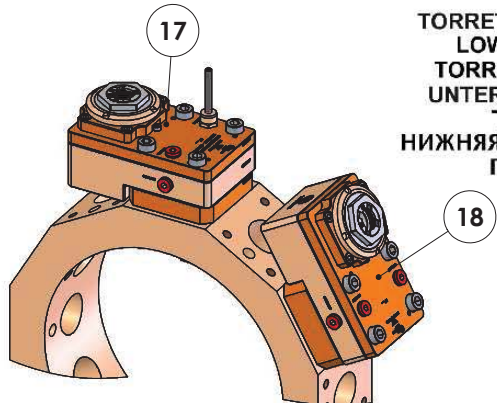

18	LT-SD40ER25F OFS72H96LR RFAYMU	NEW	05156400-R011
17	LT-S D40ER25F OFS72H86LR AY MU	NEW	05156100-R011
16	LT-A D40 ER20F LR 1:2KR H100MU		05153300-R011
15	LT-S D40ER20F OF78LR1:3KRH90MU		05153200-R011
14	LT-S2 D40 ER20F-20F H122 1:2MU		05153000-R011
13	LT-S D40DIN138-22OFS72LR H93MU		05155900-R011
12	LT-A ST65 D40 C16 H105 MU	NEW	05163500-R011
12	LT-A ST35 D40 C12 CR-AY H90 MU	*	05155700-R011
11	LT-A D40 ER25F-25F L-R H100 MU		05155200-R011
10	LT-S D40ER20F OFS78LR 1:3H90MU		05155100-R011
9	LT-T D40 ER16F H63-132 MU		05154200-R011
8	LT-A D40 ER25 L H100 1:2MU	*	05154500 R011
7	LT-A D40 ER20F L-R H100 1:2 MU		05154800-R011
6	LT-A D40 DIN138-22 L-R H100 MU		05154900-R011
5	LT-A D40 ER32F L-R H100 MU	NEW	05163400-R011
5	LT-A D40 ER32F RF L-R H100 MU	NEW	05163300-R011
5	LT-A D40ER25F LR RF-HPR H100MU	NEW	05163600-R011
5	LT-A D40 ER25-F RF L-R H100 MU		05154400-R011
5	LT-A D40 ER25-F L-R H100 MU		05154700-R011
4	LT-S D40 ER25F OFS72 L-R H86MU		05155800-R011
4	LT-S D40ER25FOFS72 LR RF H86MU		05153900-R011
3	LT-S D40 DIN138-22 H68 MU		05153800-R011
2	LT-S D40 ER32F H80 MU	NEW	05163200-R011
2	LT-S D40 ER32F RF H80 MU	NEW	05163100-R011
2	LT-S D40 ER25F RF H76 MU		05154100-R011
2	LT-S D40 ER25F H61 MU		05153700-R011
1	LT-S D40 ER25 H82 MU		05153600-R011

Pos	Descrizione	Note	Codice
-----	-------------	------	--------

SMW AUTOBLOK GROUP

PROPRIETA' RISERVATA - Il presente disegno e' di propriet  della MARIO PINTO SpA e non potr  essere comunicato a terzi o riprodotto in tutto o in parte senza il consenso scritto della stessa.

NOTICE - This drawing is property of MARIO PINTO SpA ITALY and shall not be reproduced, duplicated or copied in whole or in part, nor shall it be released to others without the written permission of the owner.

Diese Zeichnung darf ohne schriftliche Genehmigung von MARIO PINTO SpA ITALIEN weder kopiert noch dritten Personen mitgeteilt werden

MARIO PINTO TORINO MARIO PINTO S.p.A.		PORTAUTENSILI PER TORRETTE MOTORIZZATE		MURATEC	
SCALE/SCALA	DATE/DATE	DRAWN BY/DESEGN	CHECKED/VISTO	N.	REVISI/MODIFICA
	20-02-2015	IANNUZZI		-	17/04/2015
WEIGHT/PESO			ASSEMBLY/COMPLEX		
Raw			Machined		
Orange			Zinc		
THE COMPANY GUARDES ITS DRAWINGS ACCORDING TO THE LAW			5010 8375 -1		

* Montato sulla torretta inferiore pu  lavorare solo sul mandrino secondario
 * Mounted on lower turret can work on secondary spindle only

MANDRINO PRINCIPALE E SECONDARIO
 MAIN AND SECONDARY SPINDLE
 CABEZAL PRINCIPAL Y SECUNDARIO
 HAUPTSPINDEL / GEGENSPINDEL
 主軸および第2の軸
 ГЛАВНЫЙ И ДОПОЛНИТЕЛЬНЫЙ
 ШПИНДЕЛЬ

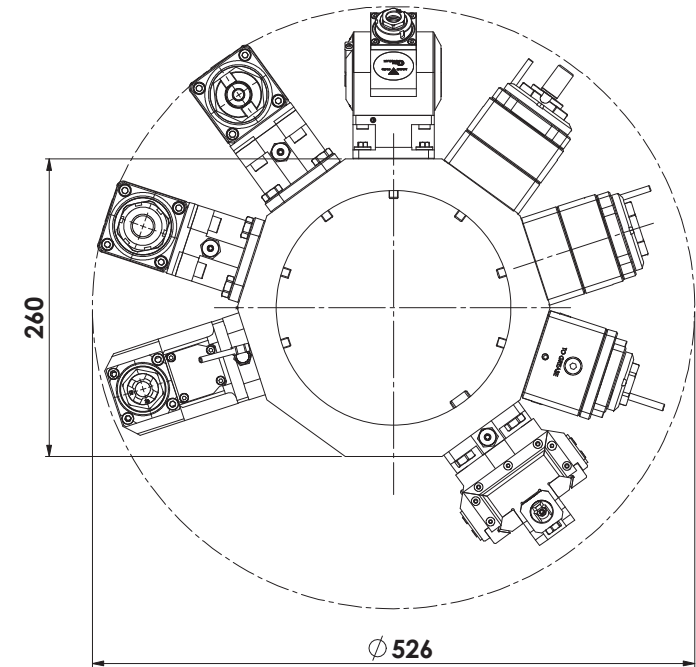
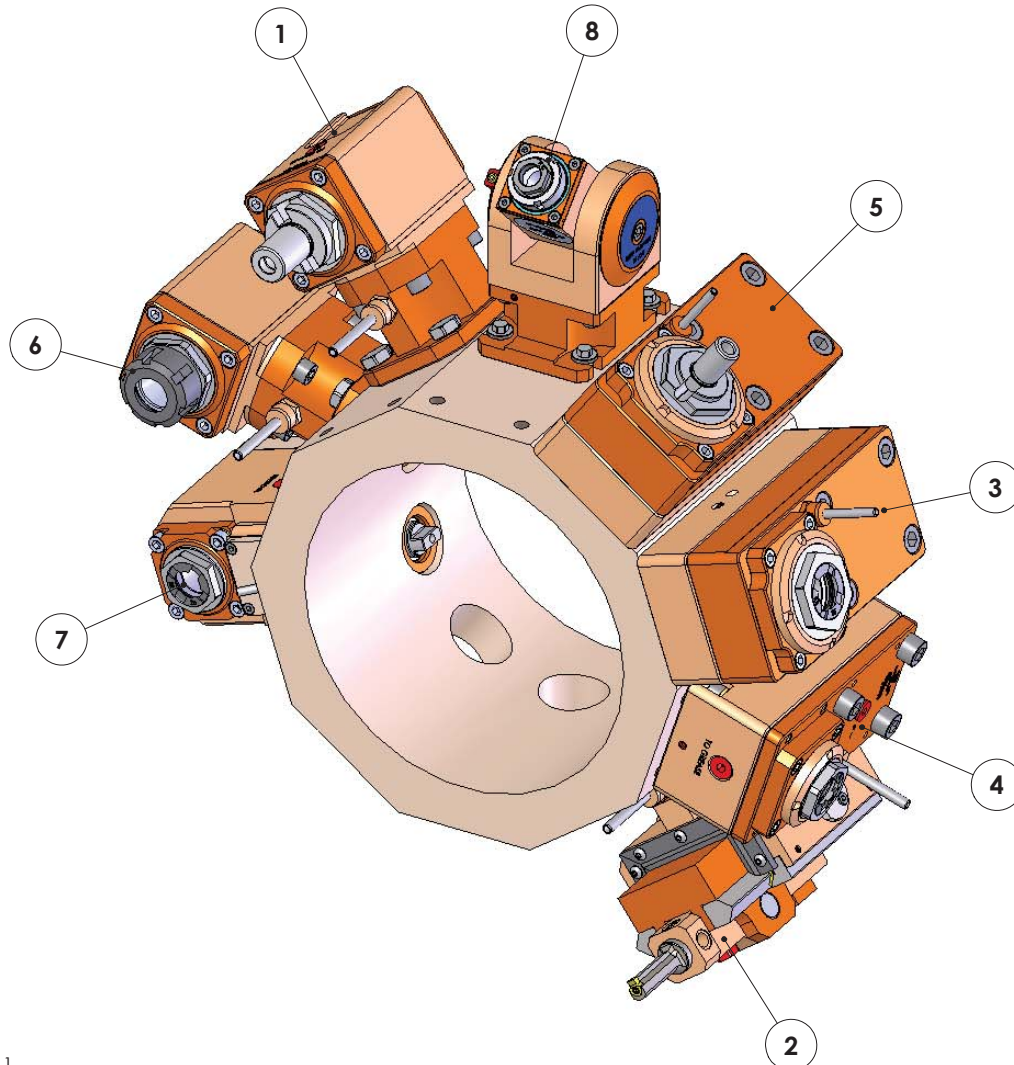

8	LT-T D40 ER16F H76-145 MU	NEW	05159800-R011
7	LT-A D40 ER20F 1:2 H100 MU	NEW	05159700-R011
6	LT-A D40 ER25 RF H100 MU	NEW	05159600-R011
6	LT-A D40 ER25 H100 MU	NEW	05159500-R011
5	LT-S D40 DIN138-16 OFS90H100MU	NEW	05159400-R011
4	LT-S D40ER20F OFS78 1:3 H90 MU	NEW	05159900-R011
3	LT-S D40 ER25F OFS90 RF H95 MU	NEW	05159300-R011
3	LT-S D40 ER25F OFS90 H95 MU	NEW	05159200-R011
2	LT-A ST35 D40 C12 H90 MU		05159000-R011
1	LT-A D40 DIN138-16 H100 MU	NEW	05158900-R011
1	LT-A D40 DIN138-22 H100 MU		05159100-R011
Pos	Descrizione	Note	Codice

SMW AUTOBLOK GROUP

PROPRIETA' RISERVATA - Il presente disegno e' di proprieta' della MARIO PINTO SpA e non potra' essere comunicato a terzi o riprodotto in tutto o in parte senza il consenso scritto della stessa.

NOTICE - This drawing is property of MARIO PINTO SpA ITALY and shall not be reproduced, duplicated or copied in whole or in part, nor shall it be released to others without the written permission of the owner.

Diese Zeichnung darf ohne schriftliche Genehmigung von MARIO PINTO SpA ITALIEN weder kopiert noch dritten Personen mitgeteilt werden

		PORTAUTENSILI PER TORRETTE MOTORIZZATE		MURATEC	
SCALE/SCALA		DATE/DATE		N. ASSEMBLY/COMPL.	
19-06-2013		DRAWN BY/DISEGN. IANNUZZI		DATA 19/06/2013	
WEIGHT/PESO		CHECKED/VISTO		FIRMA	
5010 8547		THE COMPANY GUARDS ITS DRAWINGS ACCORDING TO THE LAW		5010 8547	

MANDRINO PRINCIPALE E SECONDARIO
 MAIN AND SECONDARY SPINDLE
 CABEZAL PRINCIPAL Y SECUNDARIO
 HAUPTSPINDEL / GEGENSPINDEL
 主軸および第2の軸
 ГЛАВНЫЙ И ДОПОЛНИТЕЛЬНЫЙ
 ШПИНДЕЛЬ

NEW

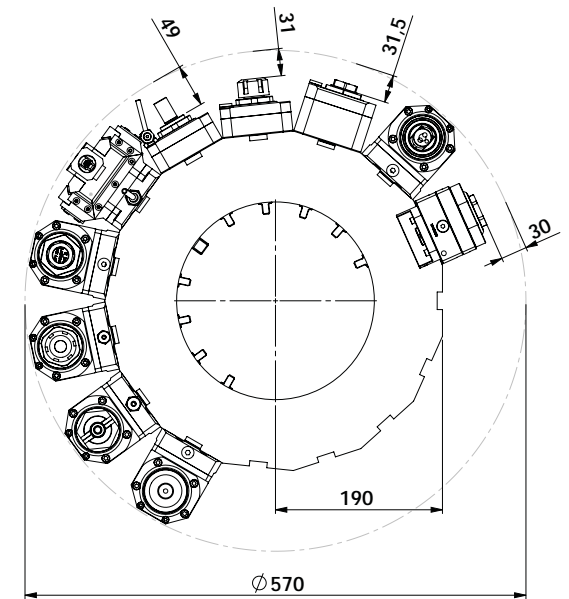
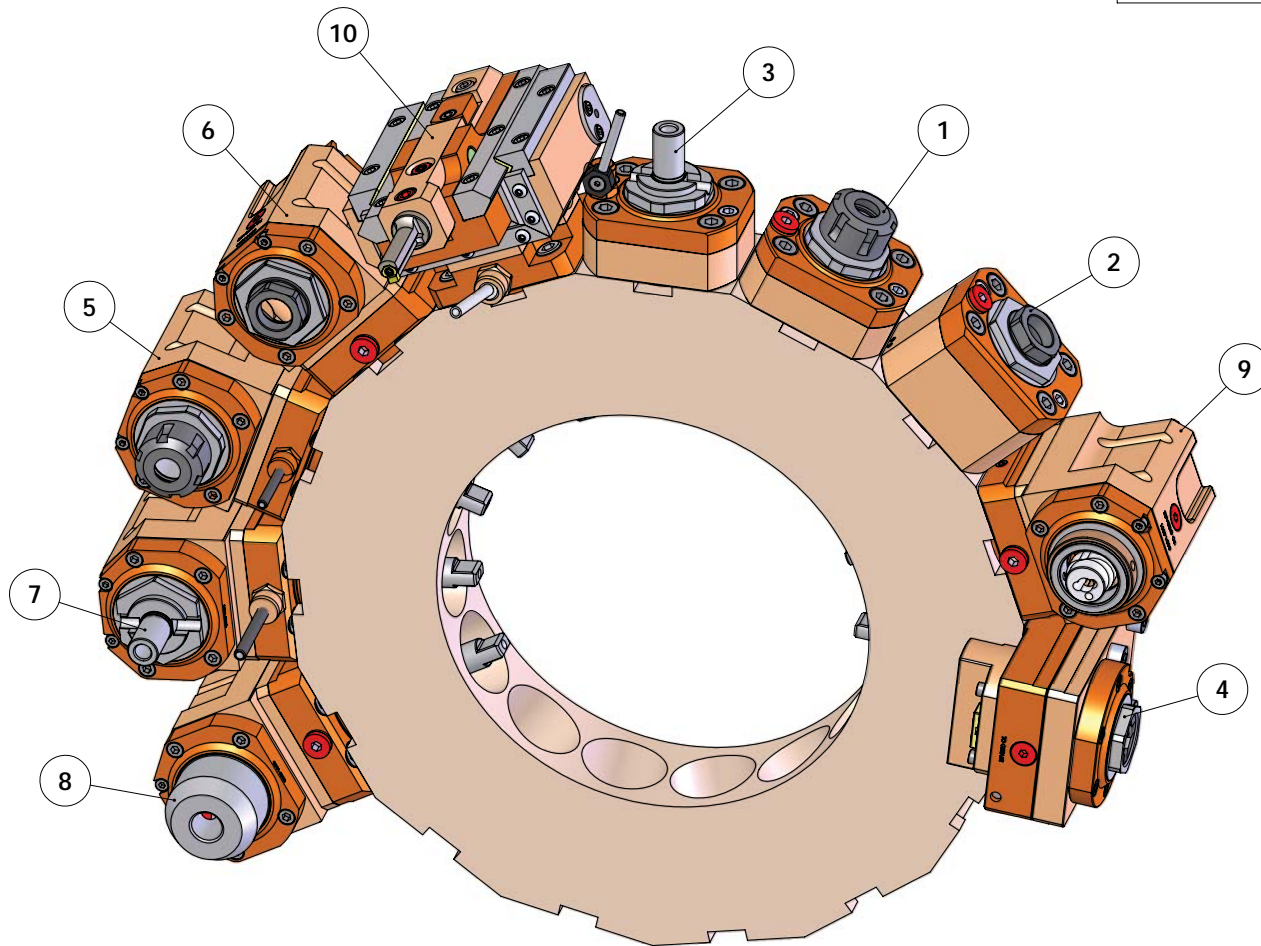

10	LT-A ST25 D44 C12 H75 NK		05014100-R011
9	LT-A D44 HSK40 L-R HRF H60	NEW	05165100-R011
8	LT-A D44 WELDON-16 RF H60 NK		05019400-R011
7	LT-A D44 DIN 138-16 L-R H60 NK		05019200-R011
6	LT-A D44 ER25F L-R HRF H60	NEW	05165000-R011
6	LT-A D44 ER25F L-R RF H60 NK		05014500-R011
6	LT-A D44 ER20F L-R HRF 1:2 H60	NEW	05165600-R011
5	LT-A D44 ER25 L-R H60 NK		05019000-R011
5	LT-A D44 ER25 L-R RF H60 NK		05019100-R011
5	LT-A D44 ER20 L-R H60 NK		05014200-R011
5	LT-A D44 ER20 L-R RF H60 NK		05014400-R011
4	LT-S D44 ER20F OFS49.5 HRF H65	NEW	05165500-R011
3	LT-S D44 DIN138-16 H46 NK		05014700-R011
2	LT-S D44 ER25F RF H62 NK		05014000-R011
1	LT-S D44 ER25 H64 NK		05014900-R011
1	LT-S D44 ER25 RF H64 NK		05014600-R011
1	LT-S D44 ER20 H64 NK		05014800-R011
1	LT-S D44 ER20 RF H64 NK		05014300-R011
Pos	Descrizione	Note	Codice

SMW AUTOBLOK GROUP

PROPRIETA' RISERVATA - Il presente disegno e' di proprieta' della MARIO PINTO SpA e non potra' essere comunicato a terzi o riprodotto in tutto o in parte senza il consenso scritto della stessa.

NOTICE - This drawing is property of MARIO PINTO SpA ITALY and shall not be reproduced, duplicated or copied in whole or in part, nor shall it be released to others without the written permission of the owner.

Diese Zeichnung darf ohne schriftliche Genehmigung von MARIO PINTO SpA ITALIEN weder kopiert noch dritten Personen mitgeteilt werden

MARIO PINTO S.p.A. TORINO		PORTAUTENSILI PER TORRETTE MOTORIZZATE		MURATEC	
SCALE/SCALA	DATE/DATE	DRAWN BY/DISEGN.	CHECKED/VISTO	N.	REVISED/MODIFICA
	24-09-2015	IANNUZZI		5011001	01/10/2015
WEIGHT/PESO			ASSEMBLY/COMPLESS.		
Raw Coarse			THE COMPANY GUARDS ITS DRAWINGS ACCORDING TO THE LAW		
			5010 8573		

MANDRINO PRINCIPALE E SECONDARIO
MAIN AND SECONDARY SPINDLE
CABEZAL PRINCIPAL Y SECUNDARIO
HAUPTSPINDEL / GEGENSPINDEL
主軸および第2の軸
ГЛАВНЫЙ И ДОПОЛНИТЕЛЬНЫЙ ШПИНДЕЛЬ

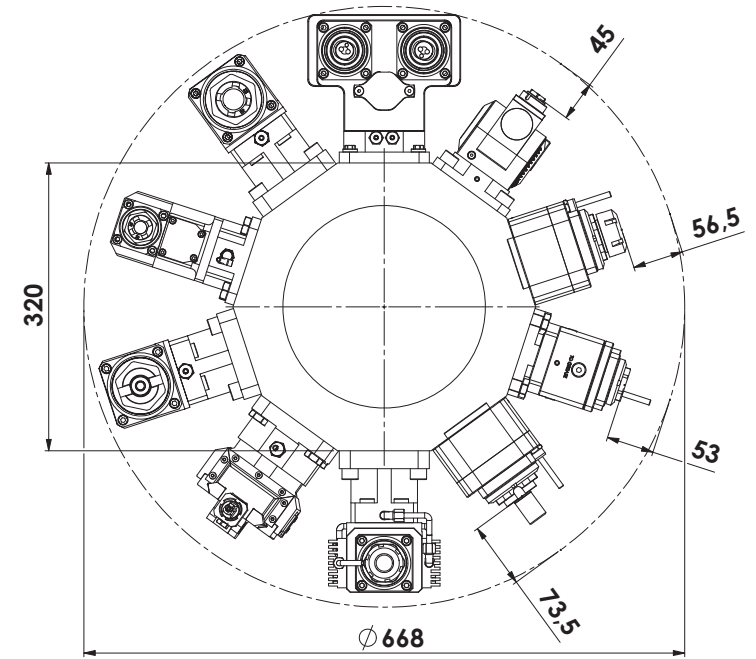
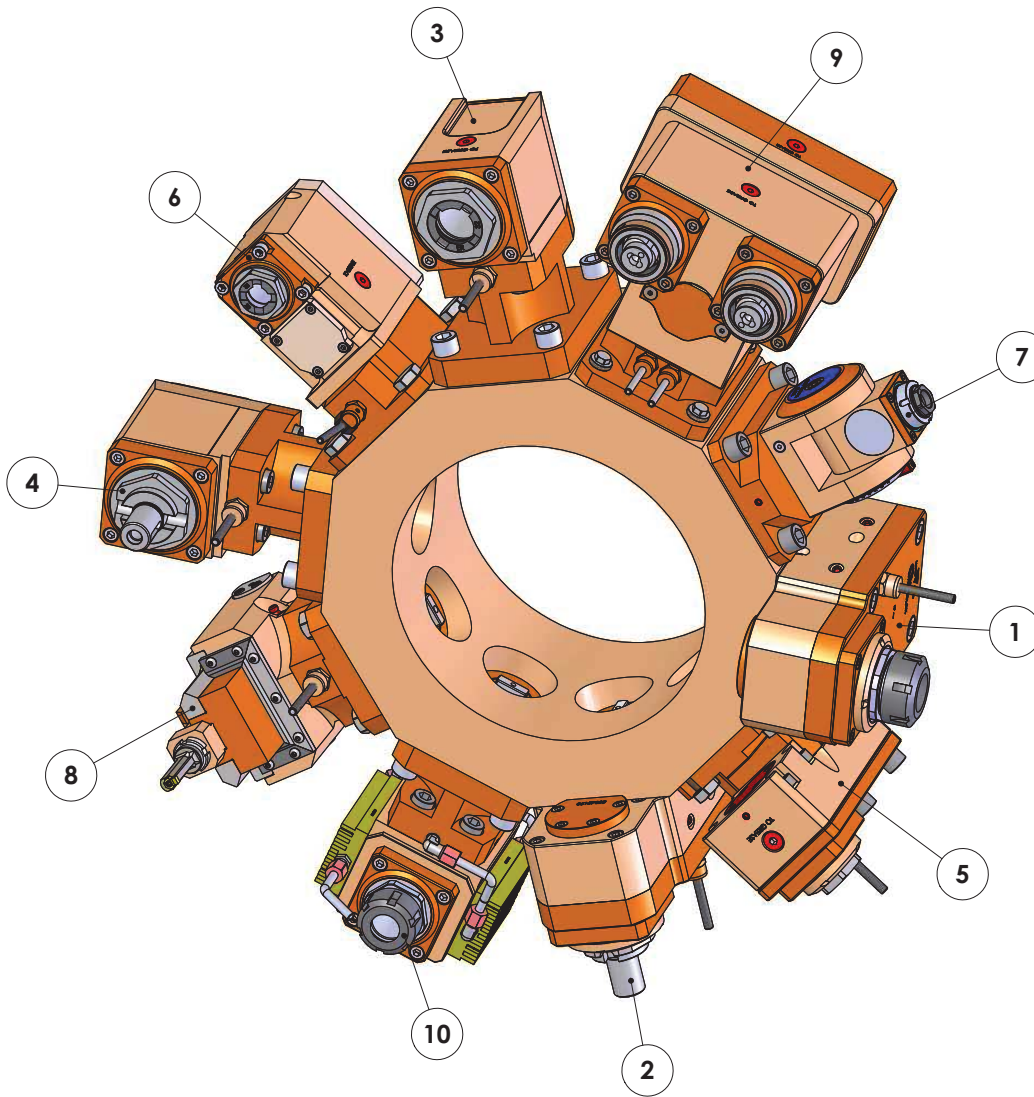

10	LT-A D55 ER25 LR 1:2 H125 MU	NEW	05158700-R011
10	LT-A D55 ER25 LR KR 1:2 H125MU	NEW	05158600-R011
9	LT-A2 D55 HSK40 I-88 LR H125MU		05158400-R011
8	LT-A ST35 D55 C12 CR-AY H125 MU		05158300-R011
7	LT-T D55 ER16F H63-129 MU		05158200-R011
6	LT-A D55 ER20F L-R H125RF1:2MU		05157800-R011
6	LT-A D55 ER20F L-R H125 1:2 MU		05157700_R011
5	LT-S D55 ER20F OFS78 RF 1:3 MU		05158100-R011
5	LT-S D55 ER20F OFS78 1:3H122MU		05157900-R011
4	LT-A D55 DIN138-22 L-R H125 MU		05157500-R011
3	LT-A D55 ER32F L-R RF H125 MU		05157400-R011
3	LT-A D55 ER32F L-R H125 MU		05157300-R011
2	LT-S D55 DIN138-22OFS100H110MU		05157200-R011
1	LT-S D55 ER32 RF OFS100 H118MU		05157100-R011
1	LT-S D55 ER32 OFS100 H118 MU		05157000-R011
Pos	Descrizione	Note	Codice

SMW AUTOBLOK GROUP

PROPRIETA' RISERVATA - Il presente disegno e' di proprieta' della MARIO PINTO SpA e non potra' essere comunicato a terzi o riprodotto in tutto o in parte senza il consenso scritto della stessa.

NOTICE - This drawing is property of MARIO PINTO SpA ITALY and shall not be reproduced, duplicated or copied in whole or in part, nor shall it be released to others without the written permission of the owner.

Diese Zeichnung darf ohne schriftliche Genehmigung von MARIO PINTO SpA ITALIEN weder kopiert noch dritten Personen mitgeteilt werden

		PORTAUTENSILI PER TORRETTE MOTORIZZATE		MURATEC	
SCALE/SCALA A2		DATE/DATE 25-02-2015		DRAWN BY/DESN. D. JALLIN	
WEIGHT/PESO 184.900 Kg		CHECKED/VISTO icannuzzi		DATA 17/04/2015	
THE COMPANY GUARDS THIS DRAWINGS ACCORDING TO THE LAW		ASSEMBLY/COMPL.		FIRMA 5010 8532	

D-44

MANDRINO PRINCIPALE E SECONDARIO
 MAIN AND SECONDARY SPINDLE
 CABEZAL PRINCIPAL Y SECUNDARIO
 HAUPTSPINDEL / GEGENSPINDEL
 主軸および第2の軸
 ГЛАВНЫЙ И ДОПОЛНИТЕЛЬНЫЙ
 ШПИНДЕЛЬ

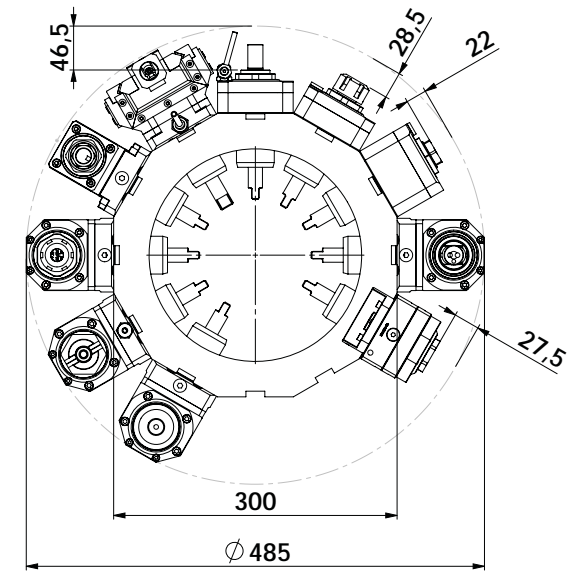
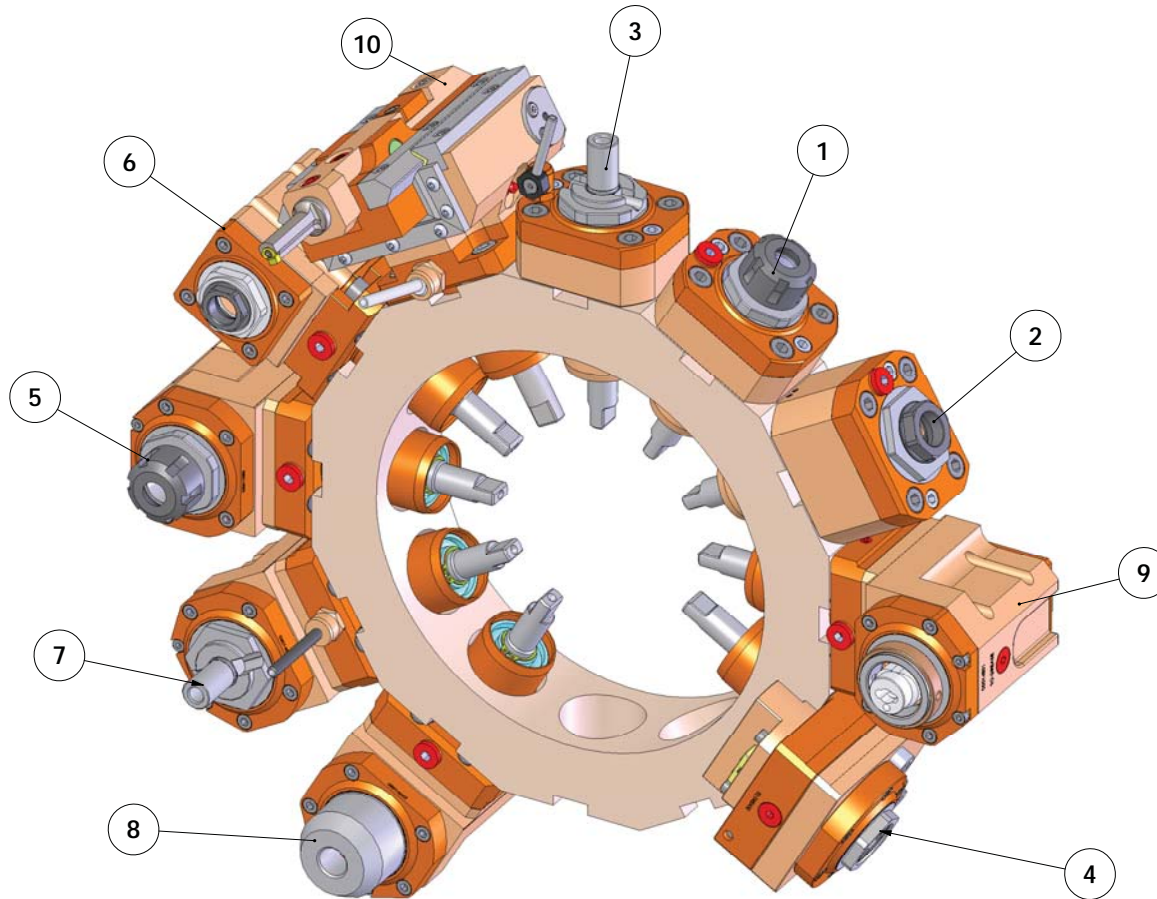

10	LT-A ST25 D44 C12 H75 NK		05014100-R011
9	LT-A D44 HSK40 L-R HRF H60	NEW	05165100-R011
8	LT-A D44 WELDON-16 RF H60 NK		05019400-R011
7	LT-A D44 DIN 138-16 L-R H60 NK		05019200-R011
6	LT-A D44 ER25F L-R HRF H60	NEW	05165000-R011
6	LT-A D44 ER25F L-R RF H60 NK		05014500-R011
6	LT-A D44 ER20F L-R HRF 1:2 H60	NEW	05165600-R011
5	LT-A D44 ER25 L-R H60 NK		05019000-R011
5	LT-A D44 ER25 L-R RF H60 NK		05019100-R011
5	LT-A D44 ER20 L-R H60 NK		05014200-R011
5	LT-A D44 ER20 L-R RF H60 NK		05014400-R011
4	LT-S D44 ER20F OFS49.5 HRF H65	NEW	05165500-R011
3	LT-S D44 DIN138-16 H46 NK		05014700-R011
2	LT-S D44 ER25F RF H62 NK		05014000-R011
1	LT-S D44 ER25 H64 NK		05014900-R011
1	LT-S D44 ER25 RF H64 NK		05014600-R011
1	LT-S D44 ER20 H64 NK		05014800-R011
1	LT-S D44 ER20 RF H64 NK		05014300-R011
Pos	Descrizione	Note	Codice

SMW AUTOBLOK GROUP

PROPRIETA' RISERVATA - Il presente disegno e' di proprieta' della MARIO PINTO SpA e non potra' essere comunicato a terzi o riprodotto in tutto o in parte senza il consenso scritto della stessa.

NOTICE - This drawing is property of MARIO PINTO SpA ITALY and shall not be reproduced, duplicated or copied in whole or in part, nor shall it be released to others without the written permission of the owner.

Diese Zeichnung darf ohne schriftliche Genehmigung von MARIO PINTO SpA ITALIEN weder kopiert noch dritten Personen mitgeteilt werden

MARIO PINTO TORINO MARIO PINTO S.p.A.		PORTAUTENSILI PER TORRETTE MOTORIZZATE		NAKAMURA TOME	
SCALE/SCALA	DATE/DATE	DRAWN BY/DISEGN.	CHECKED/VISTO	N.	REVISED/MODIFICA
	28-09-2015	IANNUZZI			DATA
					FIRMA
					ASSEMBLY/COMPLESS.
					DRAWING/DISEGNO
					5010 8456 -1

TORRETTA SUPERIORE E INFERIORE UPPER AND LOWER TURRET

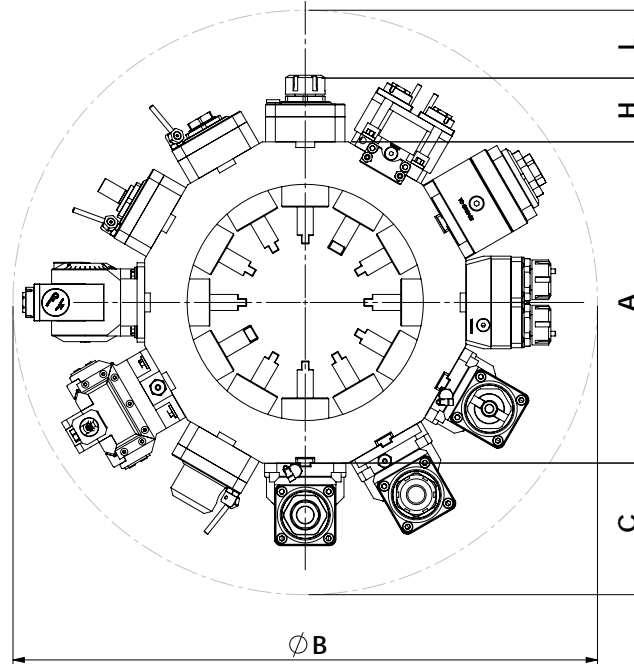
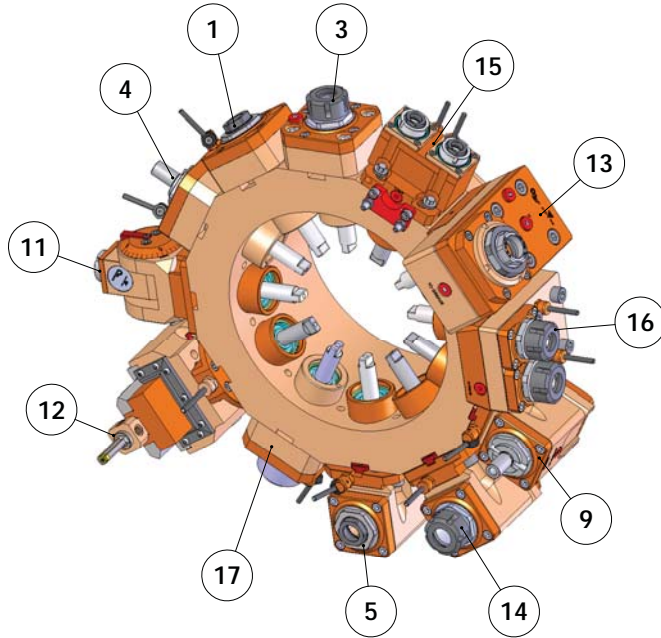

Lunghezza Utensile Tool length	L = C - H		
Macchina Machine model	A	øB	C
WT 150	340	545 upper turret	102.5
		580 lower turret	120
570 left turret		115	
647 right turret		153.5	
WTS 150	375	600	112.5
WTW 150			

17	LT-S D55 WELDON20 H77 NK	NEW	05017600-R011
16	LT-S2 D55 ER25 OFS-57 H90 NK	NEW	05017200-R011
15	LT-S2 D55 ER16F-16F 1:1 H75 NK	NEW	05016800-R011
14	LT-A D55 ER32 2:1 H95 NK		05016500-R011
14	LT-A D55 ER25 L-R RF H65 NK		05016900-R011
14	LT-A D55 ER25 L-R H65 NK		05017000-R011
13	LT-S D55 ER20F OF78 1:3 KR H90	NEW	05017700-R011
13	LT-SD55ER32FOFS76RFH-PR H106NK		05016100-R011
13	LT-S D55 ER32F OFS76 RF H106NK		05016000-R011
12	LT-A-ST65 D55 C16 H100 NK		05015900-R011
12	LT-A ST35 D55 C12 H94 NK		05019500-R011
11	LT-T D55 ER16F H63-132 NK		05011800-R011
9	LT-A D55 DIN138-22 H65 NK		05015700-R011
9	LT-A D55 DIN138-16 H65 NK		05015600-R011
9	LT-A D55 DIN138-22 H55 NK		05015500-R011
9	LT-A D55 DIN138-16 H55 NK		05015400-R011
5	LT-A D55 ER32F H75 RFH-PR NK		05016300-R011
5	LT-A D55 ER32F H75 NK		05016400-R011
5	LT-A D55 ER32F H65 RFH-PR NK		05016200-R011
5	LT-A D55 ER32F RF 2:1 H65 NK	NEW	05017300-R011
5	LT-A D55 ER32F RF H65 NK		05015200-R011
5	LT-A D55 ER32F H65 NK		05015300-R011
5	LT-A D55 ER32F RF 2:1 H55 NK	NEW	05017100-R011
5	LT-A D55 ER32F RF H55 NK		05011200-R011
5	LT-A D55 ER32F H55 NK		05011500-R011
5	LT-A D55 ER25F RF H65 NK		05015000-R011
5	LT-A D55 ER25F H65 NK		05015100-R011
5	LT-A D55 ER25F RF H55 NK		05010900-R011
5	LT-A D55 ER25F H55 NK		05011400-R011
5	LT-A D55 ER20F LR H55 H1-25 NK	NEW	05017400-R011
4	LT-S D55 DIN138-22 H55 NK		05010100-R011
4	LT-S D55 DIN138-16 H52 NK		05011700-R011
3	LT-S D55 ER32 H67.5 NK		05010600-R012
3	LT-S D55 ER25 H70 NK		05016700-R011
3	LT-S D55 ER25 RF H70 NK		05016600-R011
1	LT-S D55 ER32F RF H52 NK		05010300-R011
1	LT-S D55 ER32F H52 NK		05011300-R011
1	LT-S D55 ER25F RF H47 NK		05010200-R011
1	LT-S D55 ER25F H47 NK		05010400-R011
Pos	Descrizione	Note	Codice

SMW AUTOBLOK GROUP

PROPRIETA' RISERVATA - Il presente disegno e' di proprieta' della MARIO PINTO SpA e non potra' essere comunicato a terzi o riprodotto in tutto o in parte senza il consenso scritto della stessa.

NOTICE - This drawing is property of MARIO PINTO SpA ITALY and shall not be reproduced, duplicated or copied in whole or in part, nor shall it be released to others without the written permission of the owner.

Diese Zeichnung darf ohne schriftliche Genehmigung von MARIO PINTO SpA ITALIEN weder kopiert noch dritten Personen mitgeteilt werden

MARIO PINTO TORINO MARIO PINTO S.p.A.		PORTAUTENSILI PER TORRETTE MOTORIZZATE		NAKAMURA TOME	
SCALE/SCALA	DATE/DATE	DRAWN BY/DISEGN.	CHECKED/VISTO	N.	REVISED/MODIFICA
	30-09-2015	TORAZZA		30/09/2015	
WEIGHT/PESO			THE COMPANY GUARDS ITS DRAWINGS ACCORDING TO THE LAW		
Raw Design			Machined Edits		
ASSEMBLY/COMPLESS.			DRAWING/DISEGNO		
			5010 8445 - 1		

**MANDRINO PRINCIPALE E SECONDARIO
MAIN AND SECONDARY SPINDLE
CABEZAL PRINCIPAL Y SECUNDARIO
HAUPTSPINDEL / GEGENSPINDEL
主軸および第2の軸
главный и дополнительный
ШПИНДЕЛЬ**

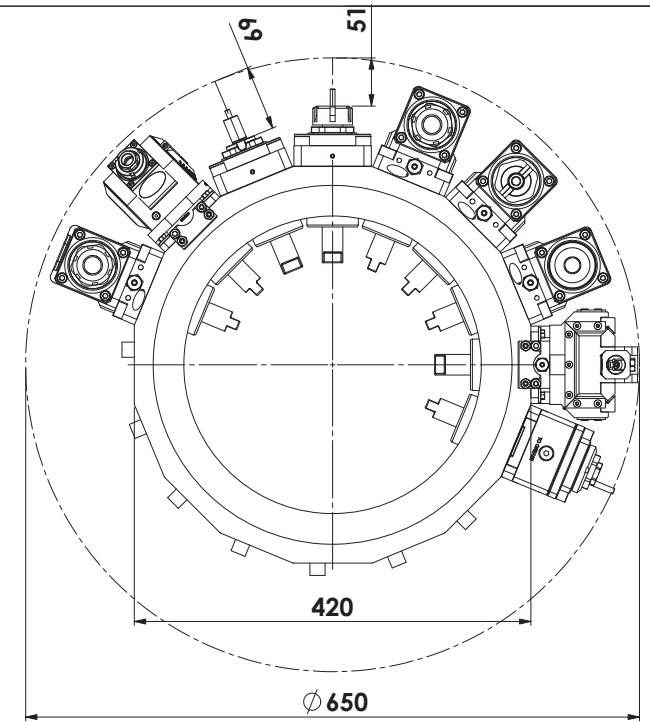
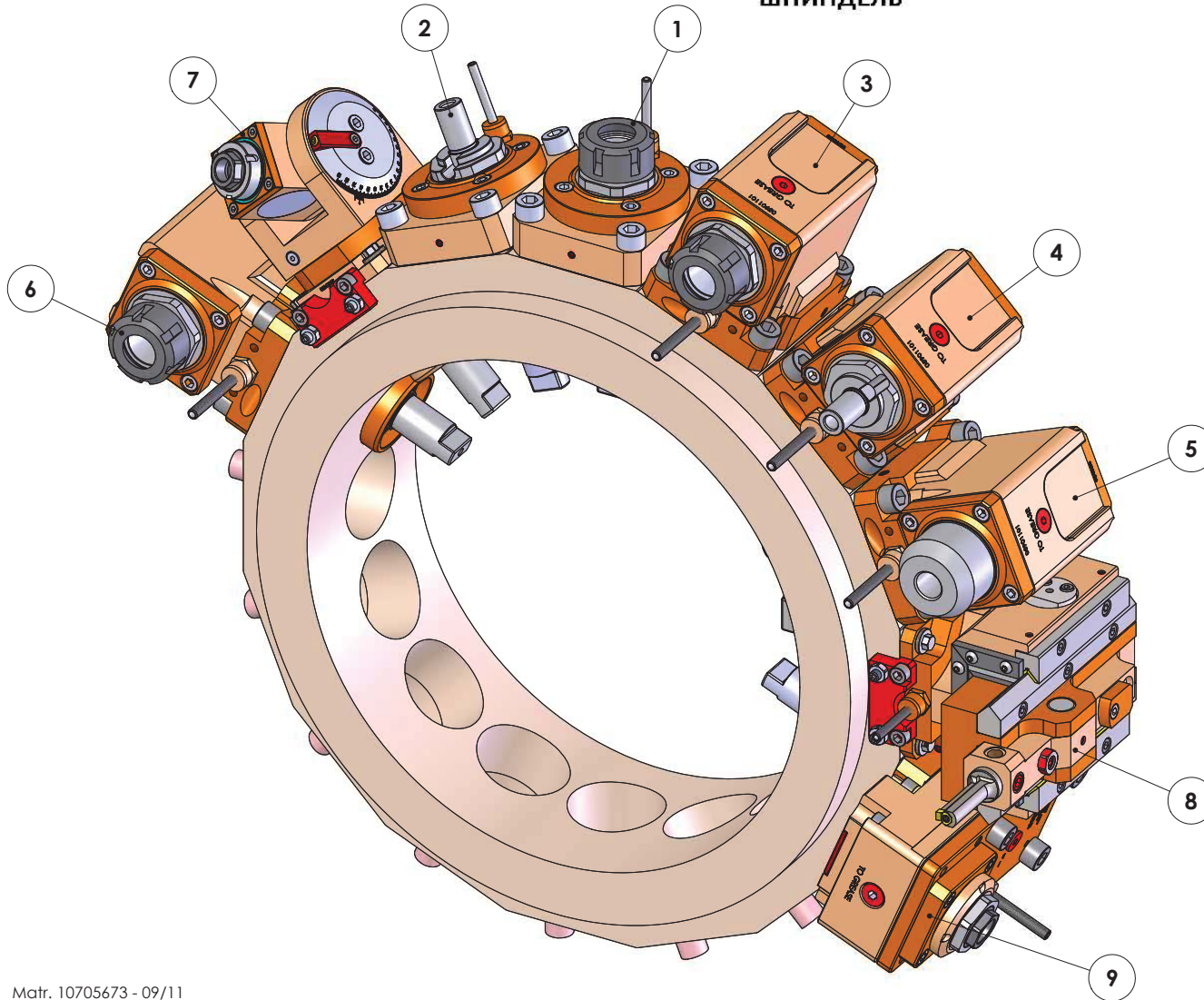

9	LT-SD55.4ER20F OF78RF1:3H90 OK	NEW	05263300-R011
9	LT-SD55.4ER20F OF78LR1:3H90 OK	NEW	05263200-R011
8	LT-A ST35 D55.4 C12 H90 OK		05263100-R011
7	LT-T D55.4 ER16F H63-132 OK		05263000-R011
6	LT-A D55.4 ER25-25 LR H65 OK		05262900-R011
5	LT-A D55.4 WELDON-16 LR H65 OK		05262800-R011
5	LT-A D55.4 WELDON-12 LR H65 OK		05262700-R011
4	LT-A D55.4 DIN138-16 LR H65 OK		05262600-R011
3	LT-A D55.4 ER25 LR RF H65 OK		05262400-R011
3	LT-A D55.4 ER25 LR H65 OK		05262500-R011
2	LT-S D55.4 DIN138-16 H46 OK		05262300-R011
1	LT-S D55.4 ER25 RF H64 OK		05262200-R011
1	LT-S D55.4 ER25 H64 OK		05262100-R011
Pos	Descrizione	Note	Codice

SMW AUTOBLOK GROUP

PROPRIETA' RISERVATA - Il presente disegno e' di proprieta' della MARIO PINTO SpA e non potra' essere comunicato a terzi o riprodotto in tutto o in parte senza il consenso scritto della stessa.

NOTICE - This drawing is property of MARIO PINTO SpA ITALY and shall not be reproduced, duplicated or copied in whole or in part, nor shall it be released to others without the written permission of the owner.

Diese Zeichnung darf ohne schriftliche Genehmigung von MARIO PINTO SpA ITALIEN weder kopiert noch dritten Personen mitgeteilt werden

MARIO PINTO TORINO MARIO PINTO S.p.A.	PORTAUTENSILI PER TORRETTE MOTORIZZATE	OKUMA
SCALE/SCALA	DATE/DATE 28-10-2014	REVISIONI N. REVISIONE/MODIFICA DATA FIRMA ASSEMBLY/COMPL. DRAWING/DISEGNO
	DRAWN BY/DISEGN. IANNUZZI	17/04/2015
	CHECKED/VISTO	
	WEIGHT/PESO Raw (kg) Machined (kg)	5010 8552
	THE COMPANY GUARDS ITS DRAWINGS ACCORDING TO THE LAW	

**MANDRINO PRINCIPALE E SECONDARIO
 MAIN AND SECONDARY SPINDLE
 CABEZAL PRINCIPAL Y SECUNDARIO
 HAUPTSPINDEL / GEGENSPINDEL
 主軸および第2の軸
 ГЛАВНЫЙ И ДОПОЛНИТЕЛЬНЫЙ
 ШПИНДЕЛЬ**

MACCHINA	L = C - H		
	A	ØB	C
LB2000 EX	340	580	120
LB2500 EX	340	580	120
LB3000 EX(M)	340	580	120
LB3000 EX(MY)	340	570	115
LB3000 EX(MW)	340	580	120
MULTUS U3000/U4000	340	620	140

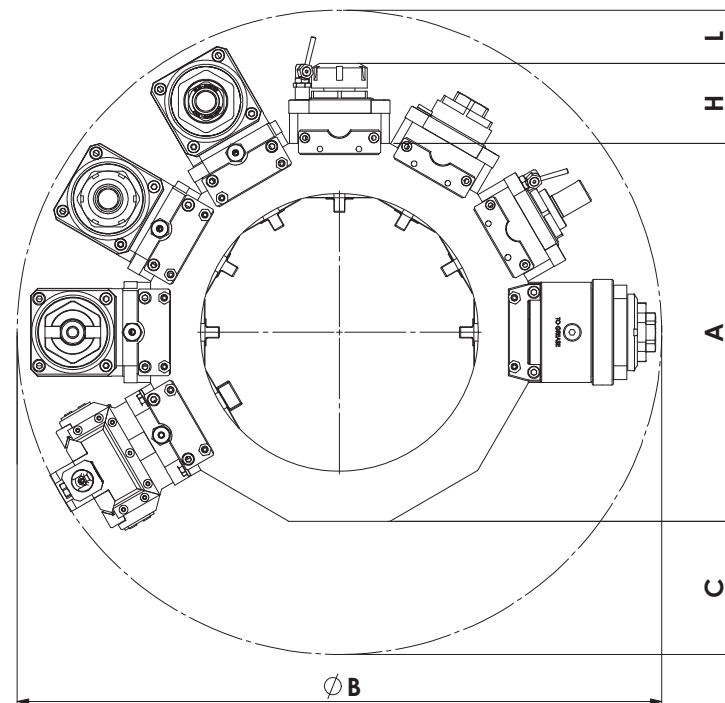
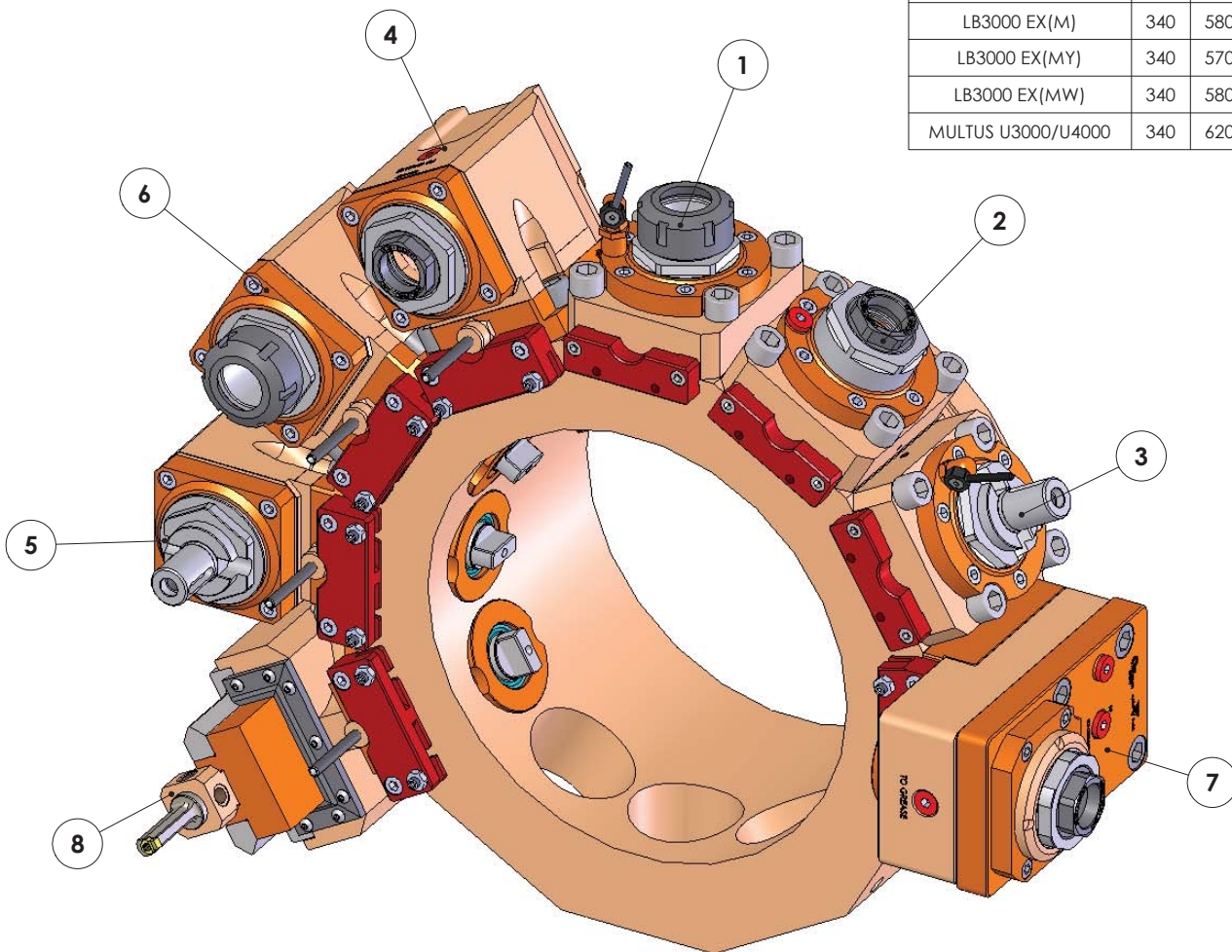

8	LT-A ST35 D60 C12 H100 OK	05067700-R011	
7	LT-S D60 ER32F OF76 RF H106 OK	05067800-R011	
6	LT-A D60 ER32 L-R RF H70 OK	05068800-R011	
6	LT-A D60 ER32 L-R H70 OK	05068700-R011	
5	LT-A D60 DIN138-22 H70 OK	05068600-R011	
4	LT-A D60 ER32F L-R RF H70 OK	05068400-R011	
4	LT-A D60 ER32F L-R H70 OK	05068300-R011	
3	LT-S D60 DIN138-22 H55 OK	05068500-R011	
2	LT-S D60 ER32F H62 OK	05068100-R011	
2	LT-S D60 ER32F RF H62 OK	05068200-R011	
1	LT-S D60 ER32 RF H72 OK	05068000-R011	
1	LT-S D60 ER32 H72 OK	05067900-R011	
Pos	Descrizione	Note	Codice

SMW AUTOBLOK GROUP

PROPRIETA' RISERVATA - Il presente disegno e' di propriet  della MARIO PINTO SpA e non potra' essere comunicato a terzi o riprodotto in tutto o in parte senza il consenso scritto della stessa.

NOTICE - This drawing is property of MARIO PINTO SpA ITALY and shall not be reproduced, duplicated or copied in whole or in part, nor shall it be released to others without the written permission of the owner.

Diese Zeichnung darf ohne schriftliche Genehmigung von MARIO PINTO SpA ITALIEN weder kopiert noch dritten Personen mitgeteilt werden

MARIO PINTO TORINO MARIO PINTO S.p.A.	PORTAUTENSILI PER TORRETTE MOTORIZZATE	OKUMA
SCALE/SCALA	DATE/DATE 04-06-2014	ADMINISTRATOR 04/06/2014
WEIGHT/PESO	DRAWN BY/DISEGN. TORAZZA P.	DATA
Raw Design	CHECKED/VISTO	FIRMA
Machined Design	N. ASSEMBLY/COMPL.	DRAWING/DISEGNO
THE COMPANY GUARDS ITS DRAWINGS ACCORDING TO THE LAW		5010 8448

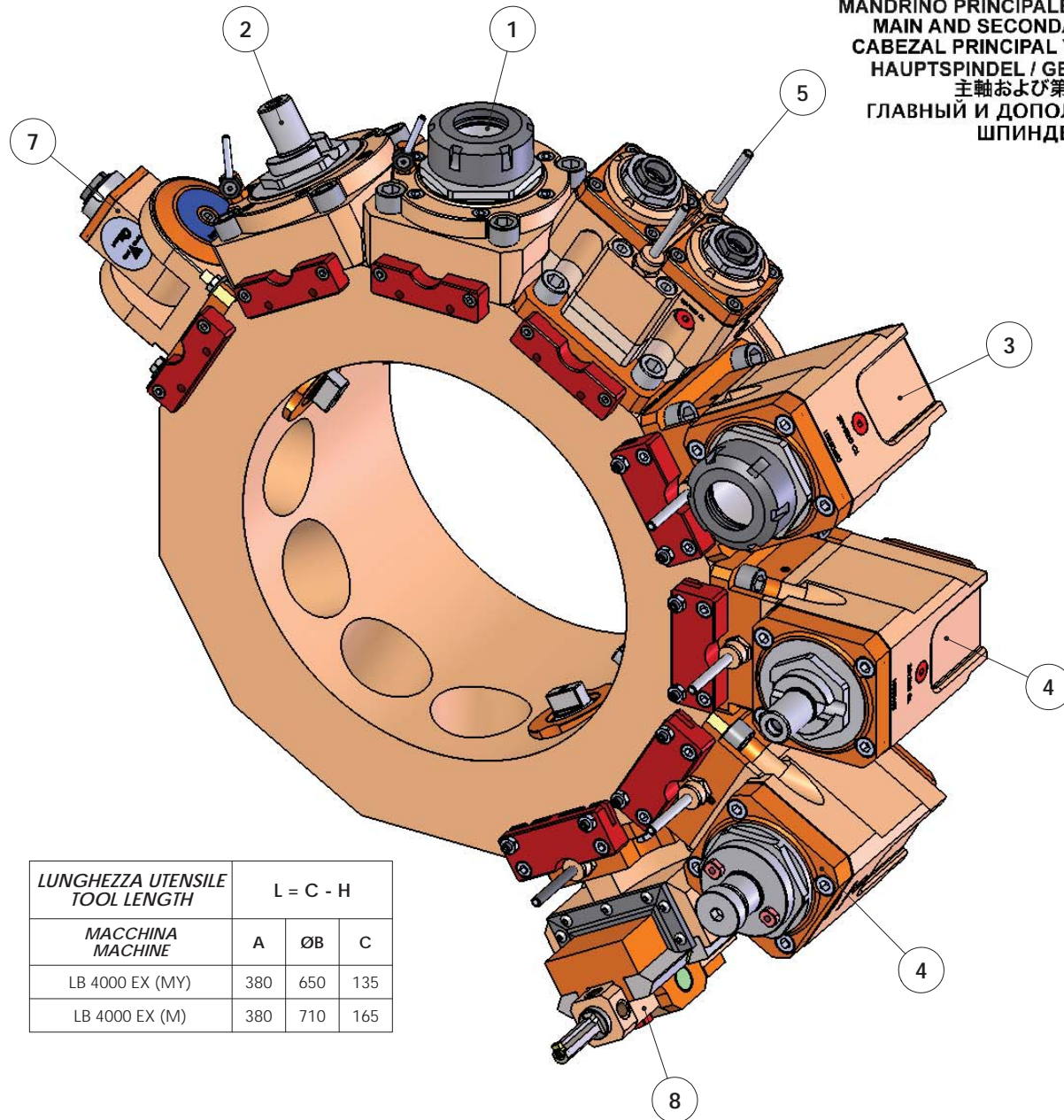

**MANDRINO PRINCIPALE E SECONDARIO
MAIN AND SECONDARY SPINDLE
CABEZAL PRINCIPAL Y SECUNDARIO
HAUPTSPINDEL / GEGENSPINDEL
主軸および第2の軸
Главный и дополнительный
ШПИНДЕЛЬ**

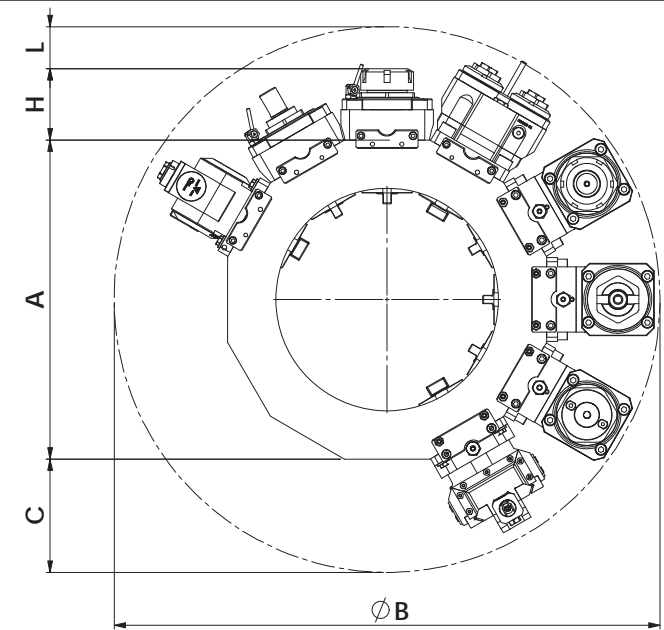

LUNGHEZZA UTENSILE TOOL LENGTH	L = C - H		
	A	ØB	C
MACCHINA MACHINE			
LB 4000 EX (MY)	380	650	135
LB 4000 EX (M)	380	710	165

8	LT-A ST65 D60 C16H107 CR-AY OK	NEW	05065300-R011
8	LT-A ST65 D60 C16 H107 OK	NEW	05065400-R011
8	LT-A ST35 D60 C12 H97 OK		05069900-R011
7	LT-T D60 ER25 LR H70.5-165 OK		05065800-R011
7	LT-T D60 ER20F LR H71-151 OK		05065900-R011
7	LT-T D60 ER16F LR H63-120 OK		05066000-R011
5	LT-S2 D60 ER20F-20F H105 1:2OK		05065500-R011
5	LT-S2 D60 ER20F-20F H105 1:1OK		05065600-R011
4	LT-A D60 FRES D1.00" H85 OK		05069600-R011
4	LT-A D60 DIN138-27 H85 OK		05069500-R011
4	LT-A D60 DIN138-22 H85 OK		05069800-R011
3	LT-A D60 ER40 RF H85 2:1 OK		05264000-R011
3	LT-A D60 ER40 RF H85 OK		05069400-R011
3	LT-A D60 ER40 H85 OK		05069300-R011
2	LT-S D60 FRES D1.00" H65 OK		05069700-R011
2	LT-S D60 DIN138-22 H65 OK		05069200-R011
1	LT-S D60 ER40 RF H85 OK		05069000-R011
1	LT-S D60 ER40 H85 OK		05069100-R011
Pos	Descrizione	Note	Codice

SMW AUTOBLOK GROUP

PROPRIETA' RISERVATA - Il presente disegno e' di
proprietà della MARIO PINTO SpA e non potrà essere
comunicato a terzi o riprodotto in tutto o in parte
senza il consenso scritto della stessa.

NOTICE - This drawing is property of MARIO PINTO SpA
ITALY and shall not be reproduced, duplicated or
copied in whole or in part, nor shall it be released
to others without the written permission of the owner.

Diese Zeichnung darf ohne schrift-
liche Genehmigung von MARIO PINTO
SpA ITALIEN weder kopiert noch
dritten Personen mitgeteilt werden

MARIO PINTO TORINO MARIO PINTO S.p.A.	PORTAUTENSILI PER TORRETTE MOTORIZZATE	OKUMA
SCALE/SCALA	DATE/DATA 26-11-2014	DRAWN BY/DISEGN. D. JALLIN
WEIGHT/PESO	CHECKED/VISTO	N. REVISED/MODIFICA
Raw Design	Machine ESB	DATA FIRMA
THE COMPANY GUARDS ITS DRAWINGS ACCORDING TO THE LAW		ASSEMBLY/COMPL. DRAWING/DISEGNO
		5010 8449

**MANDRINO PRINCIPALE E SECONDARIO
 MAIN AND SECONDARY SPINDLE
 CABEZAL PRINCIPAL Y SECUNDARIO
 HAUPTSPINDEL / GEGENSPINDEL
 主軸および第2の軸
 ГЛАВНЫЙ И ДОПОЛНИТЕЛЬНЫЙ
 ШПИНДЕЛЬ**

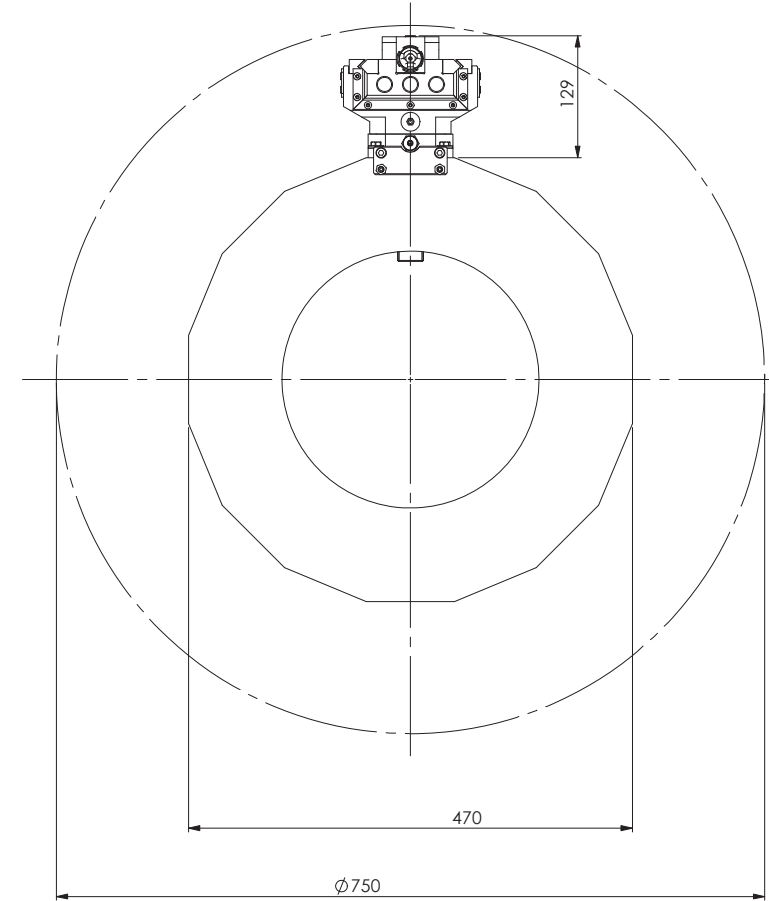
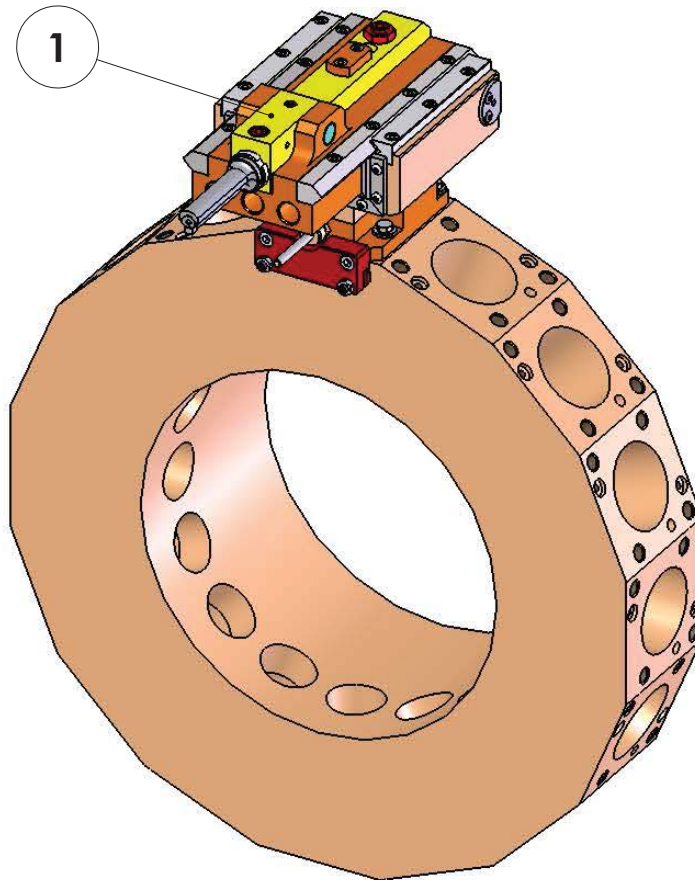

1	LT-A ST65 D60 C16H105 CR-AY OK		05261000-R011
Pos	Descrizione	Note	Codice
SMW AUTOBLOK GROUP			
<small>PROPRIETA' RISERVATA - Il presente disegno e' di proprieta' della MARIO PINTO SpA e non potra' essere comunicato a terzi o riprodotto in tutto o in parte senza il consenso scritto della stessa.</small>		<small>NOTICE - This drawing is property of MARIO PINTO SpA ITALY and shall not be reproduced, duplicated or copied in whole or in part, nor shall it be released to others without the written permission of the owner.</small>	
<small>MARIO PINTO TORINO MARIO PINTO S.p.A.</small>		OKUMA	
PORTAUTENSILI PER TORRETTE MOTORIZZATE		DATA: 23/09/2015 FIRMA:	
SCALE/SCALA	DATE/DATE: 22-09-2015	DRAWN BY/DISEGN: TORAZZA P.	CHECKED/VISTO
WEIGHT/PESO: Raw Design / Machined / Polished		THE COMPANY GUARDS ITS DRAWINGS ACCORDING TO THE LAW	
		5010 8605	

TORRETTA DESTRA E SINISTRA
RIGHT AND LEFT TURRET
TORRETA DERECHA E IZQUIERDA
RECHTER UND LINKER REVOLVER
右側及び左側タレット
ПРАВАЯ И ЛЕВАЯ
РЕВОЛЬВЕРНАЯ ГОЛОВКА

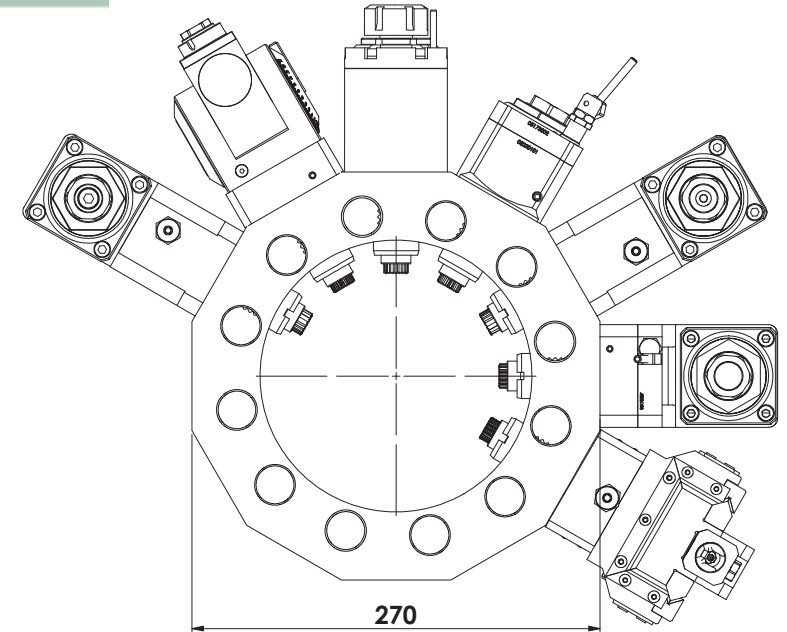
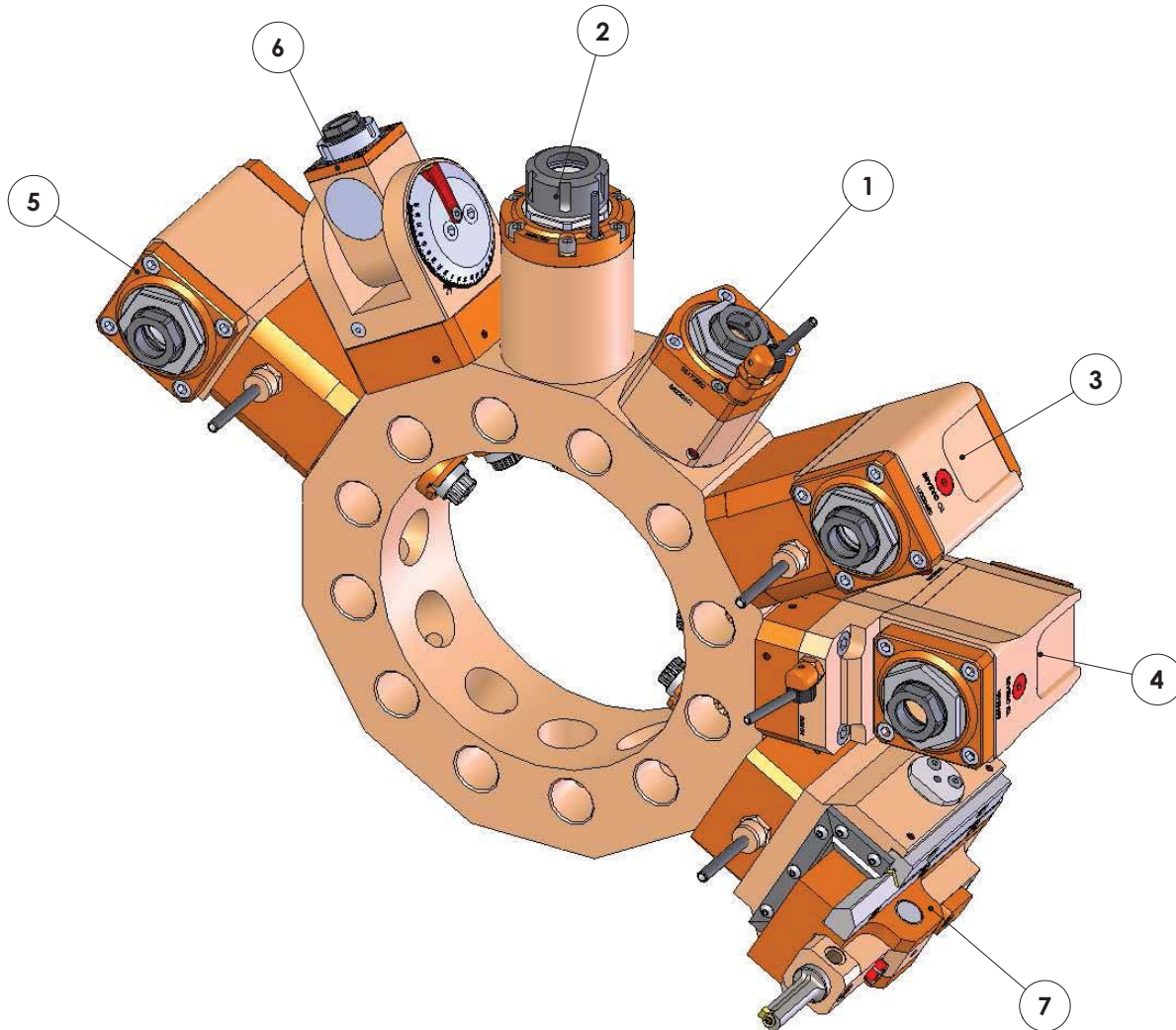

7	LT-A ST35VDI30 C12 H105 5480SA	NEW	05220900-R011
7	LT-A ST25VDI30 C12AY H105 5480	NEW	05229000-R011
6	LT-T VDI30 ER16F R-L H63-126SA		05221900-R011
5	LT-AVDI30 ER25F-25FH100 5480SA		05221400-R011
4	LT-A VDI30 ER25FRFH85OFS5480SA		05221100-R011
4	LT-A VDI30ER25F R-L H85 OFS SA		05221000-R011
3	LT-A VDI30 ER25F RF H1005480SA		05220800-R011
3	LT-A VDI30ER25F H100 DIN5480SA		05220600-R011
2	LT-S VDI30 ER25RFH112DIN5480SA		05220300-R011
2	LT-S VDI30 ER25 H112 DIN5480SA		05220200-R011
1	LT-S VDI30 ER25F H64 DIN5480 SA		05220100-R011
Pos	Descrizione	Note	Num. parte

SMW AUTOBLOK GROUP

PROPRIETA' RISERVATA - Il presente disegno e' di proprieta' della MARIO PINTO SpA e non potra' essere comunicato a terzi o riprodotto in tutto o in parte senza il consenso scritto della stessa.

NOTICE - This drawing is property of MARIO PINTO SpA ITALY and shall not be reproduced, duplicated or copied in whole or in part, nor shall it be released to others without the written permission of the owner.

Diese Zeichnung darf ohne schriftliche Genehmigung von MARIO PINTO SpA ITALIEN weder kopiert noch dritten Personen mitgeteilt werden

MARIO PINTO TORINO MARIO PINTO S.p.A.	PORTAUTENSILI PER TORRETTA MOTORIZZATE	DIN 5480	
SCALE/SCALA	DATE/DATE	DRAWN BY/DISEGN.	CHECKED/VISTO
	10-12-2014	P.L.	
WEIGHT/PESO	THE COMPANY GUARDS ITS DRAWINGS ACCORDING TO THE LAW		5010 8492
Raw Design	Machined Copy		
PAOLO		10/12/2014	
ASSEMBLY/COMPLESS.		FIRMA	

TORRETTA DESTRA
RIGHT TURRET
TORRETTA DERECHA
RECHTER REVOLVER
右側タレット
ПРАВАЯ РЕВОЛЬВЕРНАЯ ГОЛОВКА

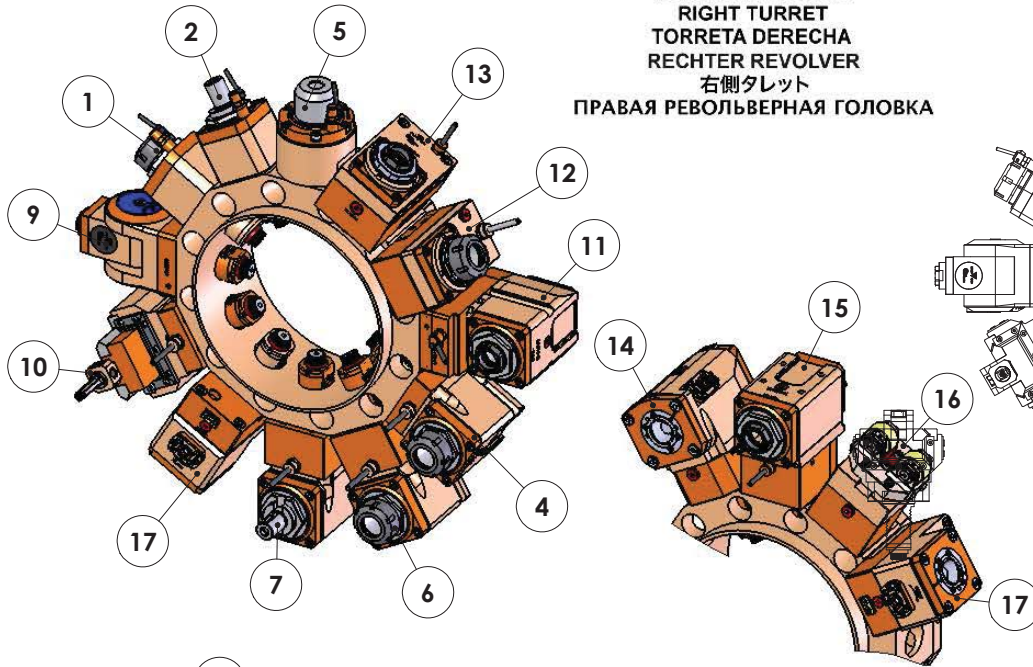

TORRETTA SINISTRA
LEFT TURRET
TORRETTA IZQUIERDA
LINKER REVOLVER
左側タレット
ЛЕВАЯ РЕВОЛЬВЕРНАЯ ГОЛОВКА

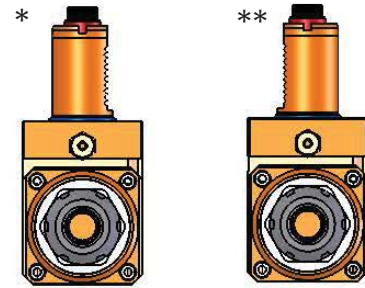
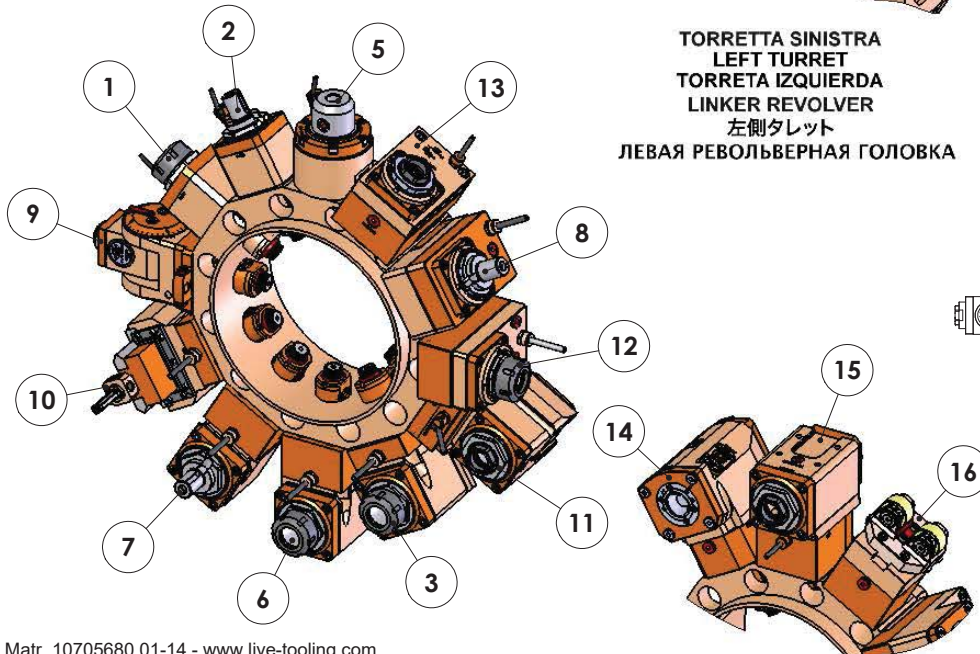

17	LT-SVDI40C4OFS50RFH-PRH1145480	NEW	05228100-R011
16	SUPP.ALB VDI40 20-100 5480 SA	NEW	05227500-R011
15	LT-A VDI40 ER32F-32F H100LR SA	NEW	05223900-R011
14	LT-A VDI40 C4 RFH-PR H100LR SA	NEW	05227400-R011
13	LT-SVDI40ER32FOFS51RF1:2H111SA	NEW	05227200-R011
13	LT-S VDI40 ER32FOFS511:2H111SA	NEW	05227300-R011
12	LT-S VDI40 ER32 OFS50 H117 SA		05223700-R011
11	LT-A VDI40 ER32F OF H90 5480SA		05223500-R011
10	LT-A ST35VDI40 C12LR H95 Y5480	NEW	05228300-R011
10	LT-A ST65VDI40 C16 H105 Y 5480	NEW	05227600-R011
10	LT-A ST35 VDI40 C12 LR H95 5480		05223800-R011
9	LT-T VDI40 ER16F H63-132 SA		05227000-R011
9	LT-T VDI40 ER20F H71-151 SA		05227100-R011
8	LT-S VDI40 DIN22OFS2:1R H100SA		05222400-R011
7	LTA VDI40DIN138-22H100LR5480SA		05222700-R011
6	LT-A VDI40 ER32 RFH100LR5480SA		05222500-R011
6	LT-A VDI40 ER32 H100 L-R5480SA		05222600-R011
5	LT-S VDI40 WELDON16H108 5480SA		05222300-R011
4	LT-A VDI40 ER32 RF LH70 5480SA	*	05223200-R011
4	LT-A VDI40 ER32 L H70 5480 SA	*	05222800-R011
3	LT-A VDI40 ER32 RF RH70 5480SA	**	05223300-R011
3	LT-A VDI40 ER32 R H70 5480 SA	**	05222900-R011
2	LT-S VDI40 DIN138-22H80 5480SA		05222200-R011
1	LT-S VDI40 ER32 RF H110 5480SA		05222100-R011
1	LT-S VDI40 ER32 H97 DIN5480SA		05222000-R011
Pos	Descrizione	Note	Codice

SMW AUTOBLOK GROUP

PROPRIETA' RISERVATA - Il presente disegno e' di propriet  della MARIO PINTO SpA e non potra' essere comunicato a terzi o riprodotto in tutto o in parte senza il consenso scritto della stessa.

NOTICE - This drawing is property of MARIO PINTO SpA ITALY and shall not be reproduced, duplicated or copied in whole or in part, nor shall it be released to others without the written permission of the owner.

Diese Zeichnung darf ohne schriftliche Genehmigung von MARIO PINTO SpA ITALIEN weder kopiert noch dritten Personen mitgeteilt werden

MARIO PINTO TORINO MARIO PINTO S.p.A.	PORTAUTENSILI PER TORRETTA MOTORIZZATE	DIN 5480
SCALE/SCALA	DATE/DATE	29/04/2013
	28-04-2015	
	D. JALLIN	
WEIGHT/PESO	THE COMPANY GUARDS ITS DRAWINGS ACCORDING TO THE LAW	5010 8536

**MANDRINO PRINCIPALE E SECONDARIO
MAIN AND SECONDARY SPINDLE
CABEZAL PRINCIPAL Y SECUNDARIO
HAUPTSPINDEL / GEGENSPINDEL
主軸および第2の軸
Главный и дополнительный
шпиндель**

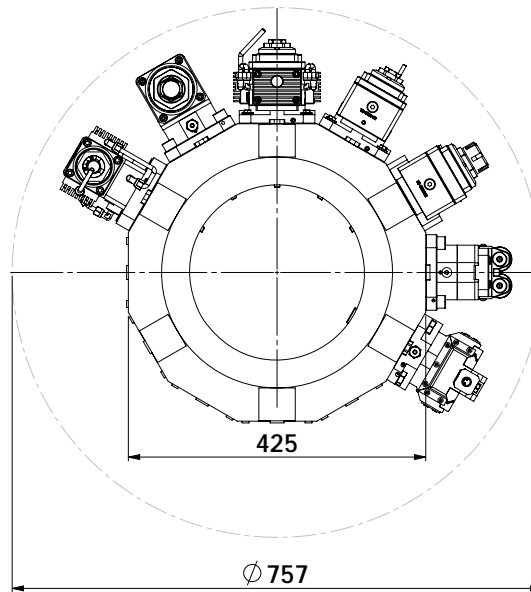
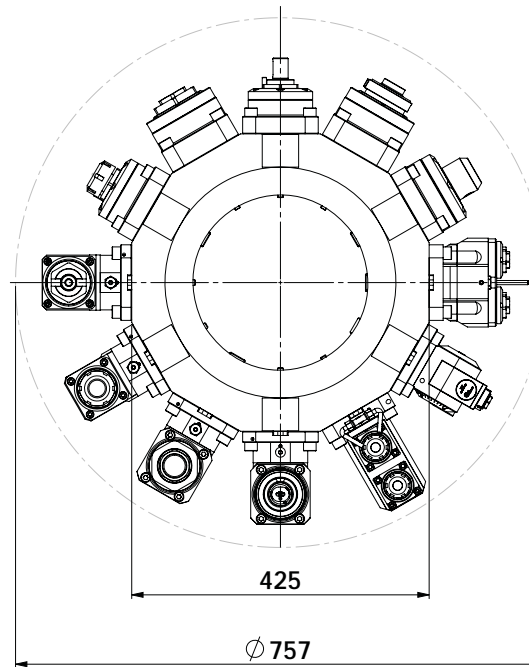
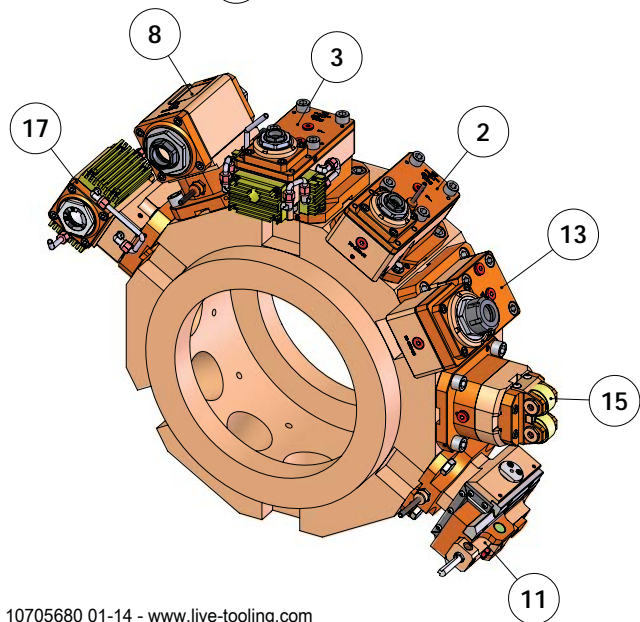
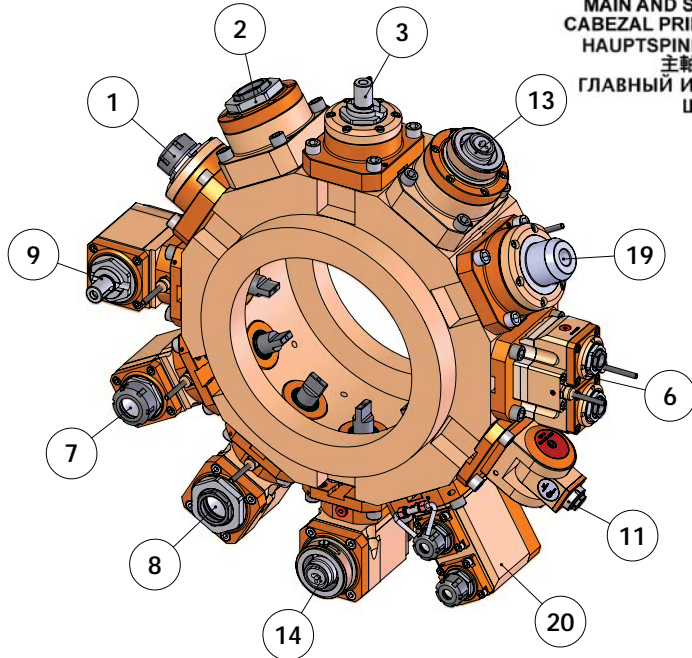

20	LT-A2V D60 ER20-20 LR OFS63 MS		05240300-R011
19	LT-S D60 WELDON 20 MS		05049900-R011
18	LT-A D60ER25F-25FKROFS 1:2 MS		05048800-R011
17	SUPP ALB AX D50-150 D60 MS		05048500-R011
17	SUPP ALB AX D10-30 D60 MS		05049400-R011
16	LT-S D60 ER32 OF76RF 1:1H130MS		05049200-R011
16	LT-S D60 ER25 OF76RF 1:1H126MS		05049300-R011
15	LT-A ST65 D60 C16 H110 MS		05049800-R011
15	LT-A ST35 D60 C12 H100 MS		05047100-R011
14	LT-A D60 HSK-63 LR RF H90 MS		05046700-R011
14	LT-A D60 HSK-40 LR RF H90 MS		05046900-R011
13	LT-S D60 HSK-63 RF H105 MS		05046600-R011
13	LT-S D60 HSK-40 RF H97 MS		05046800-R011
11	LT-T D60 ER20F H70-151 MS		05041700-R011
11	LT-T D60 ER16F H63-132 MS		05041600-R011
10	LT-A D60 ER32F-32F LR2:1H90 MS		05046500-R011
10	LT-A D60 ER32F-32F LR RF H90MS		05049700-R011
10	LT-A D60 ER32F-32F L-R H90 MS		05041400-R011
9	LT-A D60 DIN138-27 L-R H90 MS		05041200-R011
9	LT-A D60 DIN138-22 L-R H90 MS		05041300-R011
8	LT-A D60 ER40F LR RF H90 MS		05040700-R011
8	LT-A D60 ER40-F L-R H90 MS		05041000-R011
8	LT-A D60 ER32F LR RF H90 MS		05047400-R011
7	LT-A D60 ER32 LR RF H-PR H90MS		05240200-R011
7	LT-A D60 ER40 L-R 2:1 H90 MS		05049600-R011
7	LT-A D60 ER40 LR RF H90 MS		05049100-R011
7	LT-A D60 ER40 L-R H90 MS		05040600-R011
7	LT-A D60 ER32 LR RF H90 MS		05049000-R011
7	LT-A D60 ER32 L-R H90 MS		05040100-R011
6	LT-S2 D60 ER20F-20F H111 1:2MS		05042000-R011
6	LT-S2 D60 ER20F-20F H111 1:1MS		05042300-R011
4	LT-S D60ER32FOFS50RFH-PRH102MS		05240100-R011
4	LT-S D60 ER40F OFS95RF2:1H108MS		05042200-R011
4	LT-S D60 ER40F OFS95 2:1H108MS		05042100-R011
4	LT-S D60 ER32F OF76RF1:1H106MS		05047200-R011
4	LT-S D60 ER25F OF76RF1:1H104MS		05047300-R011
4	LT-S D60ER20FOF78LR1:3KR H115MS		05049500-R011
4	LT-S D60 ER20F OF78LR1:3H115MS		05041800-R011
3	LT-S D60 DIN138-27 H79 MS		05040500-R011
3	LT-S D60 DIN138-22 H77 MS		05040400-R011
2	LT-S D60 ER40F RF H93 MS		05041100-R011
2	LT-S D60 ER32F RF H90 MS		05048400-R011
1	LT-S D60 ER40 H90 MS		05040300-R011
1	LT-S D60 ER32 H96 MS		05040200-R011
Pos	Descrizione	Note	Num. parte

SMW AUTOBLOK GROUP

PROPRIETA' RISERVATA - Il presente disegno e' di proprieta' della MARIO PINTO SpA e non potra' essere comunicato a terzi o riprodotto in tutto o in parte senza il consenso scritto della stessa.

NOTICE - This drawing is property of MARIO PINTO SpA ITALY and shall not be reproduced, duplicated or copied in whole or in part, nor shall it be released to others without the written permission of the owner.

Diese Zeichnung darf ohne schriftliche Genehmigung von MARIO PINTO SpA ITALIEN weder kopiert noch dritten Personen mitgeteilt werden

MARIO PINTO TORINO MARIO PINTO S.p.A.		PORTAUTENSILI PER TORRETTE MOTORIZZATE		TAKISAWA JAPAN	
SCALE/SCALA	DATE/DATE	DRAWN BY/DISEGN.	CHECKED/VISTO	N.	REVISED/MODIFICA
-	04-03-2015	IANNUZZI		ASSEMBLY/COMPL.	DATA
WEIGHT/PESO		THE COMPANY GUARDS ITS DRAWINGS ACCORDING TO THE LAW		FIRMA	
-		-		50108600-1	