



 **DümmeL**[®]
WERKZEUGFABRIK

SET ULTRAMINI TYP DT

Multifunktionswerkzeug
zum Bohren und Ausdrehen

NEU

- Klemmhalter mit 4 Spannflächen - 90° versetzt
- Klemmhalter mit IKZ - Anschluss
- Bohrungstiefe bis 4x D
- Schneiden mit innenliegender Kühlbohrung
- High Performance Beschichtung AL41F
- Große Spantiefe beim Ausdrehen und Bohren ins Volle möglich



	Bestellnummer	Inhalt	Aktionspreis/ SET
	<p>SET-RDT-4</p> <ul style="list-style-type: none"> • Bohren und Ausdrehen (Rechte Ausführung) • D min. 3,7 	<p>Halter: 1 x 640.DT16</p> <p>Schneideinsatz: 1 x RDT.4-15 1 x RDT.4-20</p>	<p>€ 129,90</p>
	<p>SET-RDT-5</p> <ul style="list-style-type: none"> • Bohren und Ausdrehen (Rechte Ausführung) • D min. 4,7 	<p>Halter: 1 x 650.DT16</p> <p>Schneideinsatz: 1 x RDT.5-15 1 x RDT.5-25</p>	<p>€ 129,90</p>
	<p>SET-RDT-6</p> <ul style="list-style-type: none"> • Bohren und Ausdrehen (Rechte Ausführung) • D min. 5,7 	<p>Halter: 1 x 660.DT16</p> <p>Schneideinsatz: 1 x RDT.6-15 1 x RDT.6-30</p>	<p>€ 129,90</p>
	<p>SET-RDT-7</p> <ul style="list-style-type: none"> • Bohren und Ausdrehen (Rechte Ausführung) • D min. 6,7 	<p>Halter: 1 x 670.DT16</p> <p>Schneideinsatz: 1 x RDT.7-20 1 x RDT.7-35</p>	<p>€ 129,90</p>

ULTRAMINI

Typ 640.DT / 650.DT / 660.DT / 670.DT / 680.DT

Bohrungsbearbeitung
ab \varnothing 0.2 mm

Klemmhalter

ab \varnothing 4 - 8 mm
für Schneideinsatz mit
D min. 0.2 - 7.8 mm

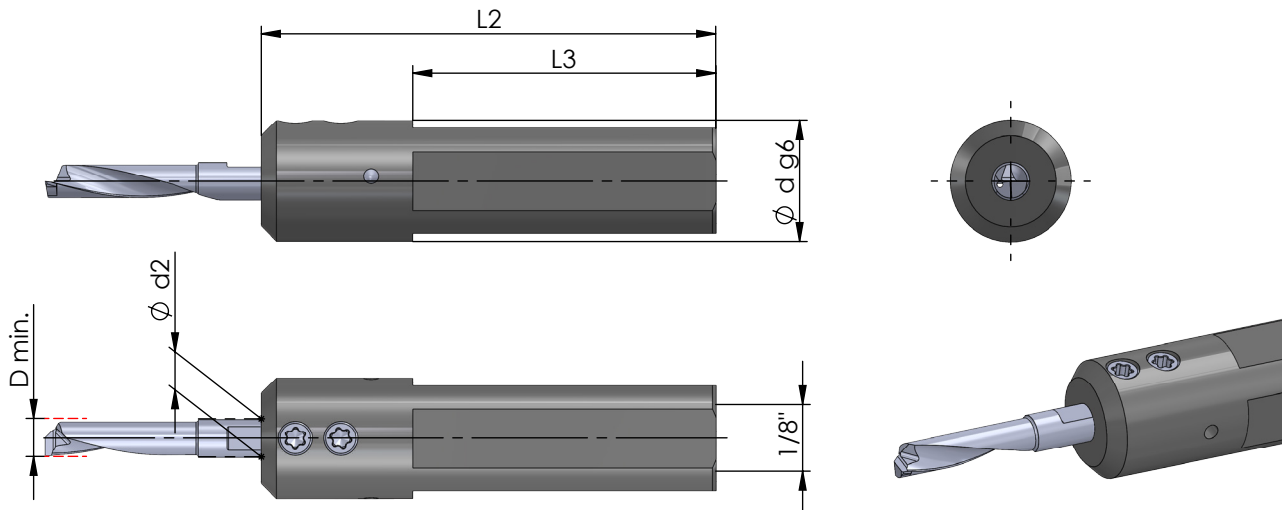

Klemmhalter für rechte und linke
Schneideinsätze einsetzbar

Abmessungen in mm

	Bestellnummer	Abmessungen			Spannschraube	Schraubenschlüssel	Anzugs- drehmoment	Schneideinsatz	
		\varnothing d g6	\varnothing d (inch)	L2					L3
neu	640.DT16	16		60	40	PT16	T10F	1.2 Nm	4
neu	640.DT1905	19.05	3/4"	60	40	PT16	T10F	1.2 Nm	4
neu	640.DT20	20		60	40	PT20	T10F	1.2 Nm	4
neu	640.DT22	22		60	40	PT20	T10F	1.2 Nm	4
neu	650.DT16	16		60	40	PT16	T10F	1.2 Nm	5
neu	650.DT1905	19.05	3/4"	60	40	PT16	T10F	1.2 Nm	5
neu	650.DT20	20		60	40	PT20	T10F	1.2 Nm	5
neu	650.DT22	22		60	40	PT20	T10F	1.2 Nm	5
neu	660.DT16	16		60	40	PT16	T10F	1.2 Nm	6
neu	660.DT1905	19.05	3/4"	60	40	PT16	T10F	1.2 Nm	6
neu	660.DT20	20		60	40	PT20	T10F	1.2 Nm	6
neu	660.DT22	22		60	40	PT20	T10F	1.2 Nm	6
neu	670.DT16	16		60	40	PT16	T10F	1.2 Nm	7
neu	670.DT1905	19.05	3/4"	60	40	PT16	T10F	1.2 Nm	7
neu	670.DT20	20		60	40	PT20	T10F	1.2 Nm	7
neu	670.DT22	22		60	40	PT20	T10F	1.2 Nm	7
neu	680.DT16	16		60	40	PT12	T10F	1.2 Nm	8
neu	680.DT1905	19.05	3/4"	60	40	PT16	T10F	1.2 Nm	8
neu	680.DT20	20		60	40	PT16	T10F	1.2 Nm	8
neu	680.DT22	22		60	40	PT16	T10F	1.2 Nm	8

ULTRAMINI

Bohrungsbearbeitung
ab $\varnothing 0.2$ mm

Typ DT

Bohren und Ausdrehen

D min. 2.9 - 7.7 mm

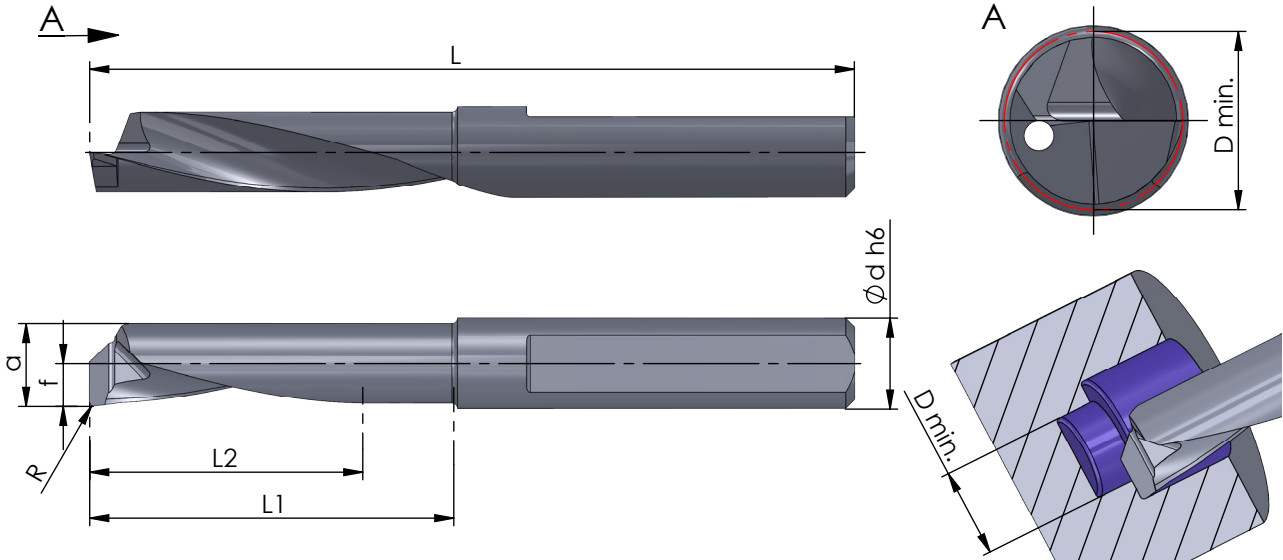

Rechts (R): wie gezeichnet
Links (L): spiegelbildlich

Abmessungen in mm

	Bestellnummer	Geometrie				L1 max. Ausdrehtiefe	L2 max. Bohrungstiefe	D min.	Ø d h6	Material				Klemmhalter Typ
		R	f	a	L					K10F	CN45F	AL41F	P07C	
neu	R/L DT.3-10	0.2	0.9	2.72	37	10	10	2.9	4			●		
neu	R/L DT.3-13	0.2	0.9	2.72	40	13	13	2.9	4			●		640.DT ... UM600H...4
neu	R/L DT.4-15	0.2	1.85	3.55	37	15	10	3.7	4			●		
neu	R/L DT.4-20	0.2	1.85	3.55	42	20	16	3.7	4			●		
neu	R/L DT.5-15	0.2	2.35	4.55	37	15	10	4.7	5			●		
neu	R/L DT.5-20	0.2	2.35	4.55	42	20	15	4.7	5			●		650.DT ... UM600H...5
neu	R/L DT.5-25	0.2	2.35	4.55	47	25	20	4.7	5			●		
neu	R/L DT.6-15	0.2	2.85	5.55	37	15	10	5.7	6			●		
neu	R/L DT.6-20	0.2	2.85	5.55	42	20	15	5.7	6			●		
neu	R/L DT.6-25	0.2	2.85	5.55	47	25	20	5.7	6			●		660.DT ... UM600H...6
neu	R/L DT.6-30	0.2	2.85	5.55	52	30	25	5.7	6			●		
neu	R/L DT.7-20	0.2	3.35	6.55	42	20	15	6.7	7			●		
neu	R/L DT.7-25	0.2	3.35	6.55	47	25	20	6.7	7			●		
neu	R/L DT.7-30	0.2	3.35	6.55	52	30	25	6.7	7			●		670.DT ... UM600H...7
neu	R/L DT.7-35	0.2	3.35	6.55	57	35	30	6.7	7			●		
neu	R/L DT.8-25	0.2	3.85	7.55	52	25	20	7.7	8			●		
neu	R/L DT.8-30	0.2	3.85	7.55	57	30	25	7.7	8			●		
neu	R/L DT.8-35	0.2	3.85	7.55	62	35	30	7.7	8			●		
neu	R/L DT.8-40	0.2	3.85	7.55	67	40	35	7.7	8			●		680.DT ...