

## Applications / Customer Benefits

- Highly precise self-centering clamping with maximum repeatability
- Compact design for better accessibility and very large drainage slots
- Jaws with SinterGrip clamping inserts for minimum workpiece clamping depth without pre-machining
- Wide clamping range
- Ideal for OP 10 and OP 20

## Technical features

- Self-centering clamping
- Clamping force up to 25 kN
- Jaw width 100 mm
- Interface for zero point systems APS / WPS

## Standard equipment

Wrench, jaws, Sintergrip inserts.

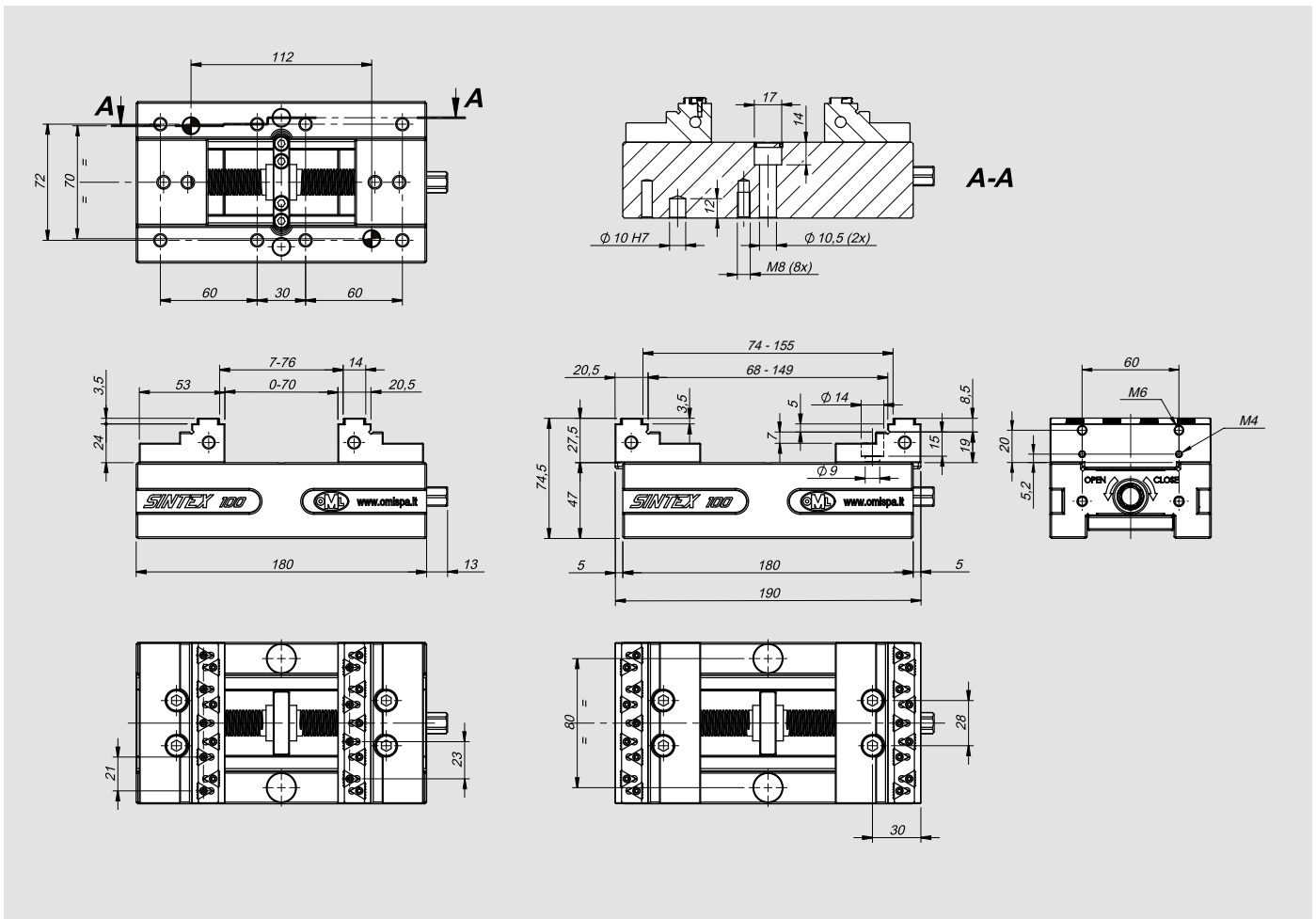

Id. No.	Type
77584911	SINTEX 100 STD
77584912	SINTEX 100 ALU
77584913	SINTEX 100 HRC